

## **IMPORTANT NOTICE**

All rights to this manual are own solely by SATEL OY (referred to in this manual as SATEL). All rights reserved. The copying of this manual, (without the written permission from the owner) by printing, copying, recording or by any other means, or the full or partial translation of the manual to any other language, including all programming languages, using any electrical, mechanical, magnetic, optical, manual or other methods or devices is forbidden.

SATEL reserves the right to change the technical specifications or functions of its products, or to discontinue the manufacture of any of its products or to discontinue the support of any of its products, without any written announcement and urges its customers to ensure, that the information at their disposal is valid.

SATEL products, software and programs are delivered "as is". The manufacturer does not grant any kind of warranty including guarantees on suitability and applicability to a certain application. Under no circumstances is the manufacturer or the developer of a program responsible for any damage possibly caused by the use of a program. The names of the programs as well as all copyrights relating to the programs are the sole property of SATEL. Any transfer, licensing to a third party, leasing, renting, transportation, copying, editing, translating, modifying into another programming language or reverse engineering for any intent is forbidden without the written consent of SATEL.

**SATEL PRODUCTS HAVE NOT BEEN DESIGNED, INTENDED NOR INSPECTED TO BE USED IN ANY LIFE SUPPORT RELATED DEVICE OR SYSTEM RELATED FUNCTION NOR AS A PART OF ANY OTHER CRITICAL SYSTEM AND ARE GRANTED NO FUNCTIONAL WARRANTY IF THEY ARE USED IN ANY OF THE APPLICATIONS MENTIONED.**

Salo, FINLAND 2006

## RESTRICTIONS ON USE

SATELLINE-2ASc, -2ASxE, -3AS(d) and -3AS(d) 869 radio modems have been designed to operate on frequency ranges, the exact use of which differs from one region and/or country to another. The user of a radio modem must take care that the said device is not operated without the permission of the local authorities on frequencies other than those specifically reserved and intended for use without a specific permit. For this reason, the notice mark has been attached to the radio modem.



The model SATELLINE-3AS(d) 869 MHz is designed to operate on the licence free frequency band of 869.400 – 869.650 MHz in accordance with recommendation CEPT/ERC/REC 70-03. This recommendation has been drawn up by the European Radiocommunications Committee (ERC) under CEPT. The transmit/receive duty cycle of any single unit is limited to 10% on this band, and a single transmission period must not exceed 36 s. In addition, the maximum allowed radiated output power is 500 mW<sub>ERP</sub>.

**WARNING!** Users of SATELLINE radio modem in North America should be aware, that due to the allocation of the frequency band 406.0 – 406.1 MHz for government use only, the use of radio modem on this frequency band without a proper permit is strictly forbidden.

## WARRANTY AND SAFETY INSTRUCTIONS

Read these safety instructions carefully before using the product:

- Warranty will be void, if the product is used in any way, which is in contradiction with the instructions given in this manual, or if the actual radio modem housing or the SATEL-321 casing has been opened or tampered with in ways contradictory to the instructions given in this manual or in other official Service Bulletins published by SATEL Oy.
- The radio modem to be contained in the SATEL-321 casing is only to be operated at frequencies allocated by local authorities, and without exceeding the given maximum allowed output power ratings. SATEL and its distributors are not responsible, if any products manufactured by it are used in unlawful ways.
- The devices mentioned in this manual are to be used only according to the instructions described in this manual. Faultless and safe operation of the devices can be guaranteed only if the transport, storage, operation and handling of the devices are appropriate. This also applies to the maintenance of the products.
- To prevent damage to the SATEL-321 battery pack and casing or the radio modem in question any terminal devices connected to the radio modem must always be switched OFF before connecting or disconnecting the serial connection cable or antenna. It should be ascertained that the different devices used have the same ground potential. Before connecting any power cables the output voltage of the power supply should be checked.

**WARNING:** The SATEL-321 battery pack must be discarded according to local environmental laws and regulations. The battery pack may contain harmful, dangerous or lethal substances, and may cause injury or loss of life if handled recklessly. Never dispose of the battery pack in fire due to a risk of explosion.

**WARNING:** The SATEL-321 casing contains parts made of aluminium, which may conduct electricity even though the surface is oxidized. Therefore the unit should under no circumstances be placed on top of any electronic or electrical parts or parts which may be powered by electricity.

## TABLE OF CONTENTS

IMPORTANT NOTICE.....	1
RESTRICTIONS ON USE .....	2
WARRANTY AND SAFETY INSTRUCTIONS.....	3
TABLE OF CONTENTS.....	4
1 INTRODUCTION .....	5
2 SATEL-321 TECHNICAL SPECIFICATIONS .....	6
3 TECHNICAL DETAILS .....	8
3.1 Battery pack.....	8
3.2 Charger.....	8
3.3 Connectors.....	8
3.4 Front panel .....	9
4 INSTALLATION .....	10
4.1 Unpacking the SATEL-321 .....	10
4.2 Installing a radio modem into the SATEL-321 casing .....	11
4.3 Charging the SATEL-321 battery pack .....	12
4.3.1 Charging for the first time .....	13
4.3.2 Normal charging.....	13
4.3.3 Replacing the battery pack.....	14
4.4 Removing a radio modem from the SATEL-321 casing .....	14
5 OPERATION.....	15
6 CHECK LIST.....	16
7 ACCESSORIES .....	17
7.1 SATEL-321 accessories.....	17
8 CARE AND MAINTENANCE.....	19
9 APPENDIX A .....	20
9.1 Connector cable layout .....	20
9.2 Connector cable schematics .....	20

## 1 INTRODUCTION

SATEL Oy is a Finnish electronics and telecommunications company specialising in the design and manufacture of wireless data communication products. SATEL designs, manufactures and sells radio modems and accessories intended for use in applications ranging from data transfer to alarm relay systems. End users of SATEL products include both public organisations and private individuals.

SATEL is the leading European manufacturer of radio modems. SATEL radio modems have been certified in most European countries and also in many non-European countries.

To expand the usefulness of SATEL radio modems a new kind of splash-proof battery pack casing designated as the SATEL-321 was designed. The use of SATEL-321 together with a radio modem constitutes a truly portable solution.

The SATEL-321 casing can house the following SATEL radio modem SATELLINE-2ASc, -2ASxE, -3AS(d) or -3AS(d) 869. The transparent window on the front side of the SATEL-321 casing allows the LCD-display of SATELLINE-3ASd and SATELLINE-3ASd 869 to be read as usual. The pushbutton switches of the radio modem can also be operated by using the thin weatherproof tactile switches.

SATELLINE radio modem has indicators (LEDs), which indicate the status of the radio modem and these may also be observed through the transparent window located on the front panel of the SATEL-321 casing. The SATEL-321 front panel has LED-indicators, which display the Power On, Charging and Battery Low states.

The top cover of the SATEL-321 has a splash proof feed through for the radio modem antenna connector and the bottom cover contains two special connectors protected by weatherproof rubber plugs. The connectors provide the connection to a charger / power supply and to a RS-232/485 connection.

Please read and follow these instructions carefully when using the SATEL-321 with any SATEL radio modem models.

**NOTE:** The SATEL-321 is intended only to be use with radio modems manufactured by SATEL.

## 2 SATEL-321 Technical specifications

SATEL-321 is a new kind of portable battery pack to be used with SATELLINE-2ASc, 2ASxE, -3AS(d) and -3AS(d) 869 type of radio modem. The radio modem fit inside the SATEL-321. The compact battery pack is splash proof (IP54), thus an additional weatherproof box is no longer needed. The total weight of the SATEL-321 package, including the battery, charger and a radio modem is only about 1 kg. For easy carrying, the casing is equipped with a removable shoulder strap. The carrying and/or mounting of SATEL-321 can also be customised to suit different needs.

Boot charging of the battery pack to full capacity requires about 3 hours and charging to 90% level only about 1.5 hour. The operation of a radio modem is possible also during charging. The operating time of the radio modem is typically between 8 - 10 hours, which facilitates prolonged operation in field applications.

The SATEL-321 casing has LED-indicators for Power ON (green), Charging (yellow) and Battery Low (red) conditions. The LED-indicators are located on the front panel (see Figure 1). Low battery charge level is also indicated by an audio signal. The front side of the SATEL-321 is equipped with tactile keys, which can be used to configure a SATELLINE-3ASd type radio modem without removing it from the SATEL-321 casing (see Figure 1).

**NOTE:** SATEL-321 has been splash proof tested according to IP54 and should not be immersed in water or subjected to unreasonably harsh conditions. Splash-proofing is dependent on the condition of the rubber plugs protecting the connectors located at the bottom of the casing and on the condition of the antenna feed through manufactured from rubber.

Figure 1.

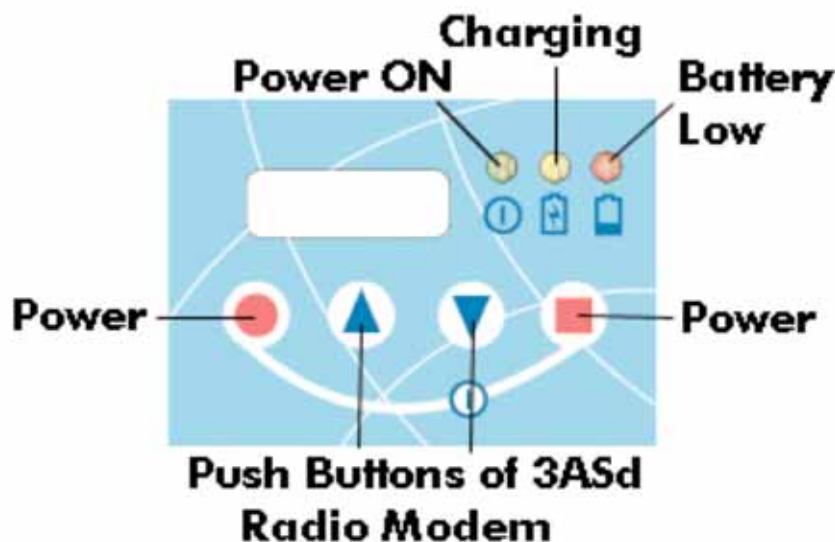

## SATEL-321 TECHNICAL SPECIFICATIONS

### BATTERY

Capacity	4.0 Ah
Type	NiMH
Nominal voltage	8.4 V

### CHARGING

Process	microprocessor controlled
Voltage	+11 ... +30 Vdc
Time to full capacity	3 h
Time to 90 % capacity	1.5 h

### CONNECTOR

Charger	3-pin round push-pull locking
RS-232/-485	(Type: HR30-6R-3P) 12-pin round push-pull locking (Type: HR30-7R-12PC)

### PHYSICAL DIMENSIONS

Size (H x W x D)	162 x 80 x 59 mm
Weight incl. radio modem	1 kg
Operating temperature range	-25 °C ... +55 °C
Charging temperature range	+5°C ... +40 °C
Protection Class	IP 54

### PUSHBUTTONS

4 tactile type push buttons	Corresponding actions as in the installed radio modem when applicable. The two pushbuttons located at the extreme left and right are used to switch the SATEL-321 battery pack (radio modem) either ON or OFF by pressing first one of the buttons down and pressing then the other shortly.
-----------------------------	---

### LED INDICATORS

Power On	Green
Charging	Yellow
Low Battery	Flashing Red

Values are subject to change without notice.

## 3 TECHNICAL DETAILS

### 3.1 Battery pack

The battery pack of SATEL-321 contains NiMH rechargeable batteries. It consists of seven battery cells (Type TH4000 Sanyo) giving a nominal voltage of 8.4 V. The capacity of the battery pack is 4000 mAh or 33.6 Wh.

### 3.2 Charger

SATEL-321 contains an internal charger. The charging process is controlled by a microprocessor, which controls the charging rate, charging voltage and current and will also prevent over-charging.

### 3.3 Connectors

The SATEL-321 contains two connectors and also one weatherproof rubber feed through for the radio modem antenna connector. The connectors are located on the bottom cover of the casing. The pin layout and connector types of the casing are described in Figure 2.

**NOTE:** The rubber plugs provided for protecting the connectors must be inserted in the appropriate connector holes in order for the unit to be weatherproof.

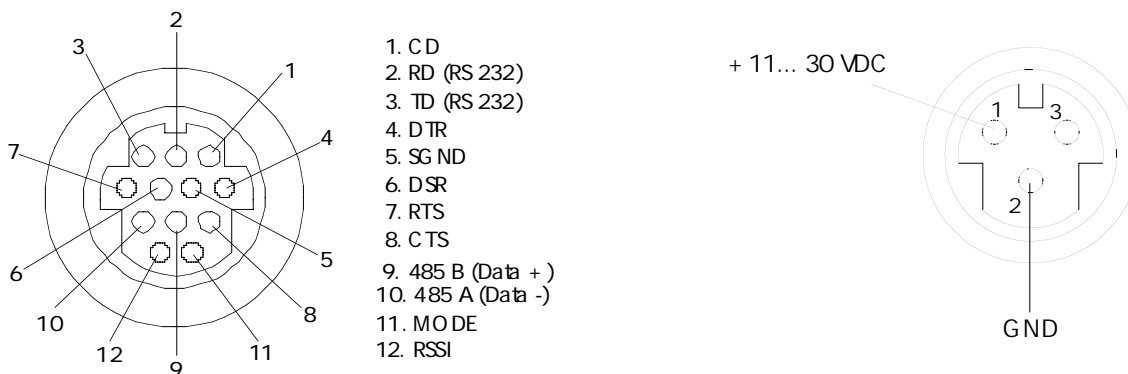

Figure 2. SATEL-321 connectors and pin layout.

### 3.4 Front panel

The front panel of SATEL-321 contains the transparent windows and the tactile pushbuttons that enable the use of different SATEL radio modem (SATELLINE-2ASc, -2ASxE, -3AS(d) and -3AS(d) 869). SATELLINE-3ASd or 3ASd 869 may be programmed on the field without removing it from the SATEL-321 casing by using the LCD-display visible through the transparent window. Other models may be programmed without removing from the SATEL-321 casing by setting the radio modem in programming mode by using the MODE-pin which is internally connected from the radio modem D-connector to the SATEL-321 data connector at the bottom of the casing (see the left picture of the Figure 2). More detailed information can be found in the User Guide of the radio modem in question. LED-indicators on the front panel display the battery pack charging status, power ON status and the low battery condition. The front panel is shown in Figure 3.

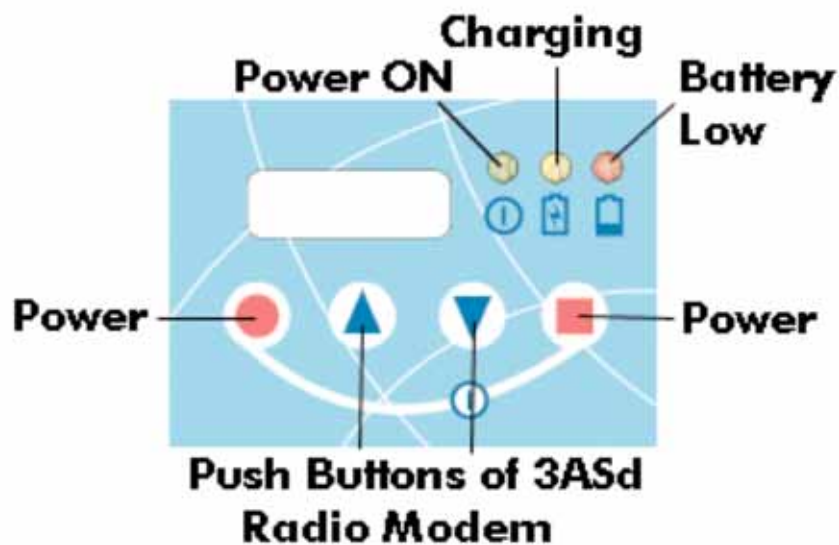

Figure 3. SATEL-321 front panel with transparent window, pushbuttons and LED-indicators.

## 4 INSTALLATION

### 4.1 Unpacking the SATEL-321

Following SATEL-321 product packages are offered by SATEL:

#### P-321-X1, including

- SATEL-321 casing with shoulder stripe
- Data cable for RS-232 interface, length 1 m
- Charging cable and AC adapter
- Mains cable, length 2 m, with European plug-in
- MINIFLEX antenna (Helix antenna for 400 – 435 or 435 – 470 MHz frequency range)
- SATEL-321 User Guide

#### P-321-X2, including

- SATEL-321 casing with shoulder stripe
- Data cable for RS-485 interface, length 1 m
- Charging cable and AC adapter
- Mains cable, length 2 m, with European plug-in
- MINIFLEX antenna (Helix antenna for 400 – 435 or 435 – 470 MHz frequency range)
- SATEL-321 User Guide

#### P-321-X3, including

- SATEL-321 casing with shoulder stripe
- Data cable for RS-232 interface, length 1 m
- Charging cable and AC adapter
- MINIFLEX antenna (Helix antenna for 400 – 435 or 435 – 470 MHz frequency range)
- SATEL-321 User Guide

#### P-321-X4, including

- SATEL-321 casing with shoulder stripe
- Data cable for RS-485 interface, length 1 m
- Charging cable and AC adapter
- MINIFLEX antenna (Helix antenna for 400 – 435 or 435 – 470 MHz frequency range)
- SATEL-321 User Guide

Please check that all listed items are included in the shipment and that they have not been damaged during transport. Report any errors to your local dealer or SATEL directly immediately.

## **4.2 Installing a radio modem into the SATEL-321 casing**

Before installing a SATELLINE-3AS(d) or 3AS(d) 869 modem into the SATEL-321 casing, the battery pack function must be selected as follows:

1. Switch the radio modem into the Programming Mode.
2. Select main menu selection "5" (Serial Port 2).
3. Enter selection "1" (Port Status).
4. Select "3" (BATT / LCD) for SATELLINE-3ASd or 3ASd 869 modems. Select "4" (BATT / NO LCD) for SATELLINE-3AS or 3AS 869 modems.
5. Save the setting.
6. Switch the radio modem back into Data Transfer Mode.

Please notice that both serial ports must be RS-232, NOT RS-485/422 and the SW-version of the SATELLINE-3AS(d) modem must be V2.16 or later.

The installation procedure is very straightforward. Please follow the steps below and see Figure 4.

**NOTE:** Switch the radio modem power **OFF** and **DISCONNECT** any cables and antennas connected to the radio modem before proceeding with the installation.

1. Unscrew the two (2) 3x16 A4-screws on the top cover of the SATEL-321 casing (see Figure 4a).
2. Carefully slide the radio modem into the casing making sure that the front side of the radio modem is pointing in the same direction as the front panel of the SATEL-321 casing and let the radio modem slide softly in until it reaches the bottom position (see Figure 4b, arrow B).
3. Push the radio modem gently in to make the connection between the D-connectors located on the inside of the SATEL-321 casing and on the bottom cover of the radio modem (see Figure 4b, arrow A).

**NOTE:** Do not use excessive force.

4. Carefully slide the rubber feed through of the antenna connector located on the top cover of the SATEL-321 over the radio modem antenna connector.

**NOTE:** Please use caution and place the weatherproof antenna feed through gently to prevent damaging the rubber material.

5. Screw back the two (2) 3x16 A4-screws to attach the top cover to the SATEL-321 casing. The maximum allowable torque is 0.8 Nm (see Figure 4c). Connect the antenna.

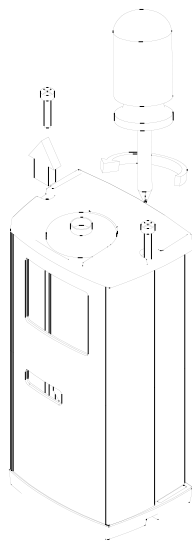

Figure 4a

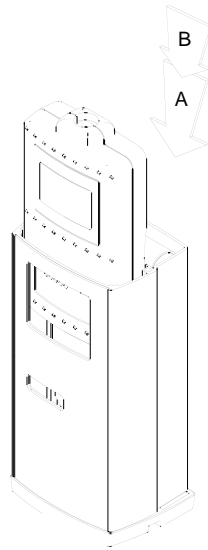

Figure 4b

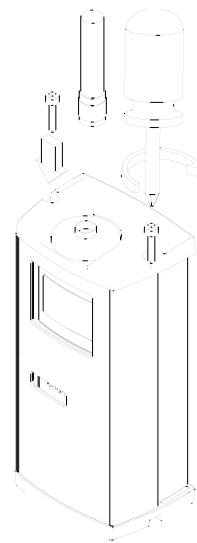

Figure 4c

### 4.3 Charging the SATEL-321 battery pack

The battery pack is charged simply by plugging the other end of the connector cable, included with the SATEL-321, into the bottom left-side connector of the SATEL-321 casing and the other end to a suitably rated power supply. A suitable power supply is available from any local SATEL dealer or from SATEL directly (see chapter 7 Accessories for ordering information).

Alternatively, the battery pack can be charged by using the supplied connector to which a suitably rated cable and power supply or adapter have been connected.

Please note the charging temperature is +5 °C ... +40 °C, while the operating temperature is -25 °C ... +55 °C

**NOTE:** In case of customer made power supply arrangements, the customer is responsible for the correctness of the installation and the suitability of the components used. Connector pin layout is described in Figure 2 and more detailed instructions are listed in Appendix A.

**WARNING!** In case of customer made power supply arrangements, SATEL strongly recommends the inclusion of a certified in-line fuse holder connected securely to the connector cable and located close to the connector to SATEL-321. Fuse rating should be checked from the Chapter 9.1 Connector cable layout.

**WARNING!** Under no circumstances is the manufacturer or the local dealer responsible for any damage possible caused by the use of customer made power supply arrangements other than those specifically recommended and/or approved by SATEL. Customers are strongly urged to verify the certification of all applied components or products and solutions and follow local laws and regulations.

The charging process is automatically monitored by the internal microprocessor of the charger circuit. The front panel LED-indicators show the level of the battery pack charge (see table below).

FRONT PANEL LED-INDICATORS		
Name	Colour	Description
Power On	Green	Radio modem power switched ON when the LED is ON
Charging	Yellow	<p><b><u>Continuously ON</u></b></p> <ul style="list-style-type: none"> <li>- Charging</li> </ul> <p><b><u>Flashing at 50/50 % ON/OFF -ratio</u></b></p> <ul style="list-style-type: none"> <li>- 90 % capacity achieved</li> </ul> <p><b><u>Flashing at 25/75 % ON/OFF -ratio</u></b></p> <ul style="list-style-type: none"> <li>- 100 % capacity achieved and the radio modem uses external electricity supply *)<sup>1</sup></li> <li>- The conditions (for example temperature) are not suitable for charging</li> </ul>
Battery Low	Red	Battery capacity low (~ 20 % of total capacity) when flashing *) <sup>2</sup>

\*)<sup>1</sup> If the radio modem is set OFF, the yellow led shuts off when 100 % capacity is achieved.

\*)<sup>2</sup> An audible warning signal is also generated when the battery pack capacity has reached a detrimentally low level. Remaining operating time is then approximately 60 - 120 minutes.

#### **4.3.1 Charging for the first time**

Since the battery pack of the SATEL-321 contains NiMH-type batteries, no special charging schemes are required even when charging the battery pack for the first time. Charging time to 90 % capacity is approximately 1.5 hours and to full capacity approximately 3 hours.

#### **4.3.2 Normal charging**

Charging may be done any time and for any length of time. The internal microprocessor controlled charging circuit will optimise the charging voltage and current for each case and will also prevent overcharging.

**NOTE:** The radio modem may be used during charging.

**NOTE:** Do not charge the SATEL-321 when vehicle is ON.

### **4.3.3 Replacing the battery pack**

The battery packs used in SATEL-321 have a long operational life span if used with care. The number of charging-discharging cycles is typically 700. In case the battery pack is damaged for some reason or the performance of the battery pack changes substantially, it should be replaced by an authorised SATEL dealer.

**WARNING:** The SATEL-321 battery pack must be discarded according to local environmental laws and regulations. The battery pack may contain harmful, dangerous or lethal substances, and may cause injury or loss of life if handled recklessly. Never dispose of the battery pack in fire due to risk of explosion.

### **4.4 Removing a radio modem from the SATEL-321 casing**

The removal of the radio modem is done in exactly the opposite way as the installation. The radio modem should be SWITCHED OFF and all cables and antennas attached to the radio modem and/or SATEL-321 casing must be removed before dismounting the radio modem.

**NOTE:** Please use caution and remove the weatherproof antenna feed through gently to prevent the rubber material from being damaged.

## 5 OPERATION

The SATEL-321 front panel contains pushbutton symbols. The front panel is a thin film which forms tactile feed through areas indicated by the four (4) pushbutton symbols (see Figure 5). The use of the pushbuttons corresponds to the use of the radio modem pushbuttons. For more information, please see the corresponding radio modem User Guide.

**NOTE:** The leftmost and the rightmost buttons may be used to switch the radio modem power ON or OFF by pressing first one of the buttons down and by then pressing the other button momentarily.

**WARNING!** If the connectors at the bottom cover of the SATEL-321 are not in use the rubber plugs must be inserted into the adjoining connector holes before taking the unit into use, otherwise the unit will NOT be weatherproof.

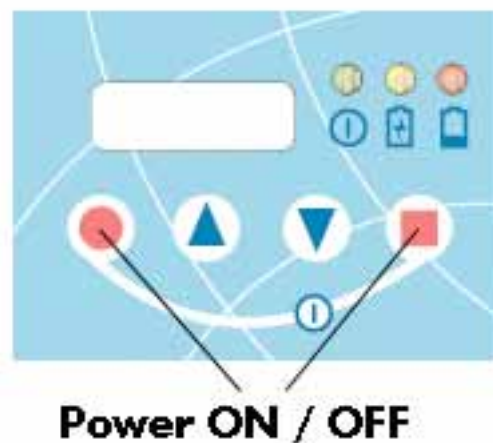

Figure 5. The pushbuttons of the SATEL-321 front panel.

## 6 CHECK LIST

The following points must be taken into account when installing a radio modem into the SATEL-321 casing:

- All operating voltages of all the equipment concerned must always be switched OFF before removing any antennas or connector cables or when preparing to open the SATEL-321 casing.
- When installing a radio modem into SATEL-321 remove ONLY the TOP COVER of the SATEL-321 casing. Removal of the bottom cover will void warranty and may cause damage to the internal connections.
- Before switching the radio modem ON the antenna should be re-connected to the antenna connector of the radio modem.
- Check the cables, the rubber plugs and the antenna feed through regularly for excessive wear caused by mobile use and/or environmental stress. Replace if necessary.

## 7 ACCESSORIES

### 7.1 SATEL-321 accessories

The following spare parts and accessories are available by ordering from any local SATEL dealer or directly from SATEL.

Part number	Description	Note
C-C-321	Charging Cable	Length 1.5 meter, with HR30-6P-3S connector / power supply wires
A-AC-321	AC Adapter TR70A15	With HR30-6P-3S connector, with charging cable
C-M	Mains Cable	Length 2 meter, with European plug-in
C-RS-321-232-F	RS-232 Interface Cable	Length 1 meter, with HR30-7P-12SC / D9 connectors
C-RS-321-485-F	RS-485 Interface Cable	Length 1 meter, with HR30-7P-12SC / D9 connectors
C-RS-321-OEW	Interface Cable	Length 1 meter, with HR30-7P-12SC connector / open ended wires

Colour coding and description of the wires of open-ended interface cable:

Pin number	Colour	Description
1	black	CD
2	white	RD (RS-232)
3	brown	TD (RS-232)
4	red	DTR
5	white / black	SGND
6	blue	DSR
7	black / red	RTS
8	pink	CTS
9	green	RS-485 B (Data +)
10	lilac	RS-485 A (Data -)
11	grey	MODE
12	yellow	RSSI

Description of the RS-232 interface cable connections:

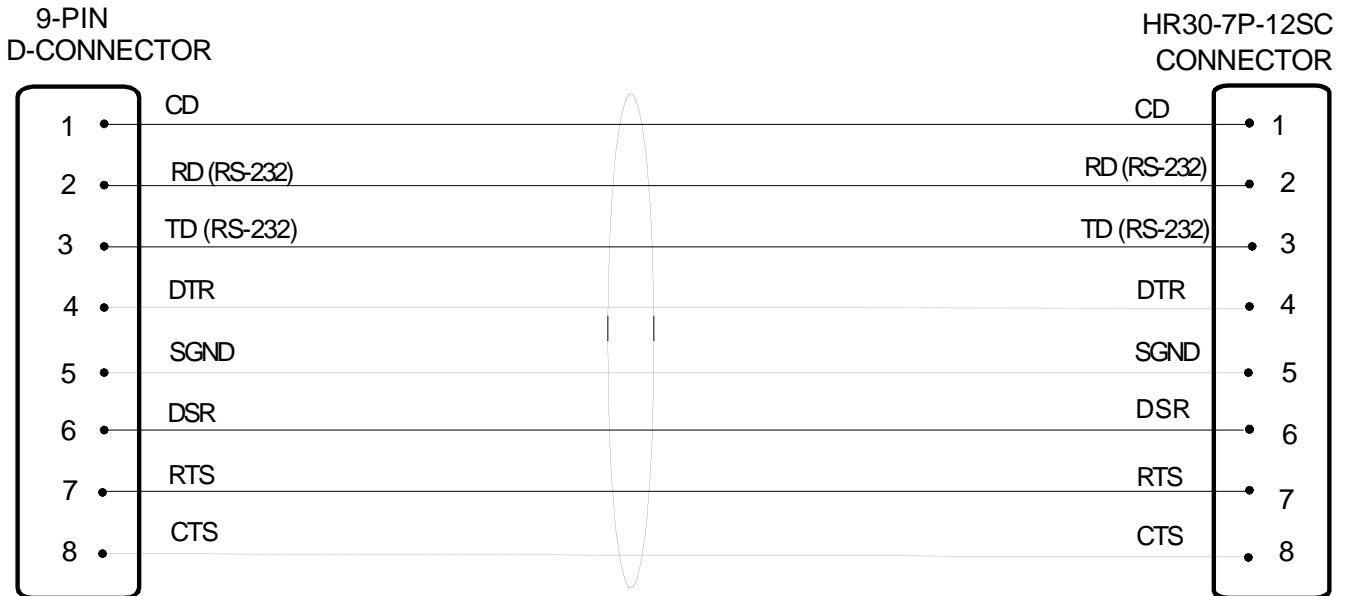

Description of the RS-485 interface cable connections:

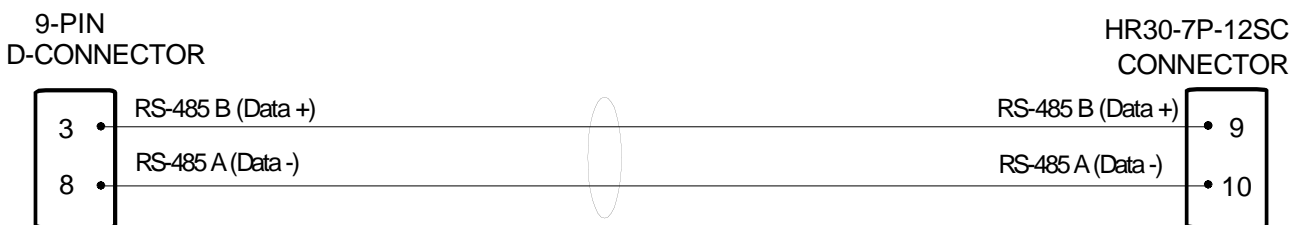

## **8 CARE AND MAINTENANCE**

The SATEL-321 casing should be cleaned on a regular basis or when dirt or other foreign material is observed on the casing. Cleaning is performed as follows:

- Use a cloth dampened slightly with normal tap water and wipes the outer surfaces clean.
- Do not use alcohol or other cleaning detergents, as these may remove the markings or damage the plastic parts.
- In environments containing seawater spray, e.g. harbours etc., salt crystals may form on the surface of the SATEL-321 after condensed water has dried. The salt may be removed by using a cloth dampened slightly with normal tap water.

## 9 APPENDIX A

The following instructions are provided only as a general guideline to users constructing customised power supply solutions.

### 9.1 Connector cable layout

The extra power connector provided with SATEL-321 should be connected to a suitably rated and properly certified power supply. A properly rated cable should be used, taking note of the maximum current required by the SATEL-321. Table below lists radio modem models, the required maximum power supply current and the corresponding required minimum cable diameter and the recommended in-line fuse rating.

Radio modem type	Maximum current [A]	Minimum cable diameter [mm <sup>2</sup> ]	In-line fuse rating [A]
SATELLINE-2ASc, 2ASxE, 3AS(d), 3AS(d) 869	3.5 A	0.75 mm <sup>2</sup>	T 5 A

Recommended connector cable diameter and in-line fuse rating.

### 9.2 Connector cable schematics

The connector, connector cable, in-line fuse and a suitable power supply are connected as indicated in Figure 7 below.

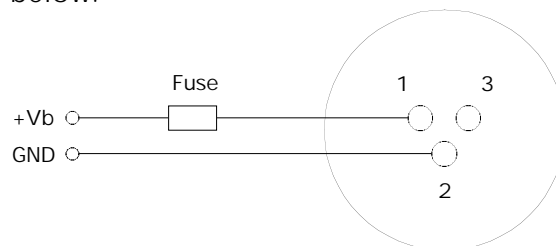

**Figure 7.** Connection diagram of the SATEL-321 power supply connector, connector cable, in-line fuse and a suitable power supply.

**WARNING!** In case of customer made power supply arrangements, SATEL strongly recommends the inclusion of a certified in-line fuse holder connected securely to the connector cable and located close to the connector to SATEL-321. Fuse rating should be checked from the Chapter 9.1 Connector cable layout.

**WARNING!** Under no circumstances is the manufacturer or the local dealer responsible for any damage possible caused by the use of customer made power supply arrangements other than those specifically recommended and/or approved by SATEL. Customers are strongly urged to verify the certification of all applied components or products and solutions and follow local laws and regulations.