



USER GUIDE

M2M

Point - to - Point

TABLE OF CONTENTS

TABLE OF CONTENTS.....1

1 THE START-UP.....3

1.1 INSTALLING THE EQUIPMENT.....3

2 CONNECTING THE INPUTS AND OUTPUTS4

2.1 STATUS DATA CONNECTIONS.....4

2.2 ANALOG CONNECTIONS5

CONNECTION EXAMPLES5

3 CHANNEL CHANGE GENERAL6

3.1 HOW TO CHANGE THE CHANNEL IN POINT-TO-POINT OPERATION..6

GENERAL

Dear customer,

This installation manual provides you in brief with all the essential information you need to get your wireless SATEL M2M Point-to-Point package in working condition. The wireless SATELLINE radio modem enables the devices' mutual communication. SATELLINE radio modems operate on so-called license-free radio frequencies and can therefore be taken into use immediately without separate permission from the authorities. All of the settings etc. needed for a connection have already been adjusted; all you have to do is the final hook-up.

Point-to-Point package

This package enables you to wirelessly control and monitor the operations of two points. The equipment makes sending and receiving of four status information (switch or other digital status) and transmitting two analog signals or measurement data possible.

The measuring sensors for analog data should be designed for 4 ... 20 mA current loop data. All changes in the input (digital or analog input) transmits to the another device as output (digital or analog output).

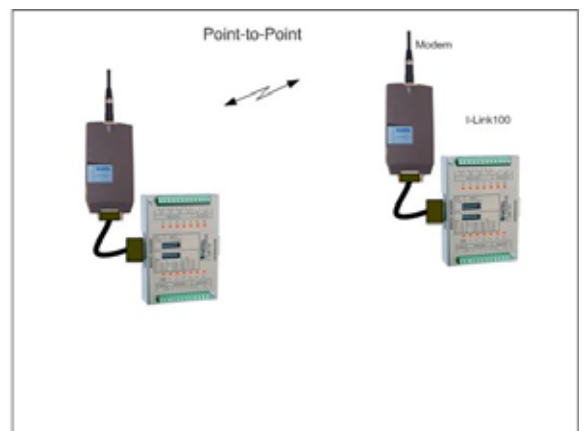

Content of the M2M package:

- 2 pcs of radio modems with antennas
- 2 pcs of I-LINK 100 I/O –converters
- 2 pcs of interface cables
- 2 pcs of power supplies
- 1 pc of installation instruction user guide for the I-LINK 100

Picture number:

- (1 and 2)
- (3)
- (4)
- (5)



1 THE START-UP

1.1 INSTALLING THE EQUIPMENT

Choose the places for installation where the products may be easily mounted. If at all possible, choose a place where there is nothing to obstruct (walls etc.) the transmission of radio signals between the devices antennas.

1. Connect antenna (2) to the radio modem (1).
2. Connect the interface cable (4) to the radio modem and the I-LINK 100 (3).
3. Connect the power supply (5) to the I-LINK 100 screw +9 ... +30 Vdc. Connect the power supply's black wire to the negative pole (-) and the red wire to the positive pole (+).
4. Make these connections to the other equipment as well

The devices should now work together.



2 CONNECTING THE INPUTS AND OUTPUTS

Once you have installed the M2M package, all you need to do is just connect the actual inputs and outputs.

Changes in the outputs occur when the corresponding inputs, for example I2, of the one device changes from 0 to +12 V, or vice versa, whereupon the contact of the output's O2 internal relay connects or opens. These contacts allow you to perform the desired function by using them to connect plus or minus to the desired device. The contact points can also be used to control a +12 ... +24 Vdc or 230 Vac device at a 2 Ampere maximum current.

Updating the analog data from the measuring sensors, for example, can be sent to another I-LINK 100 with the TIME setting, according to the chosen time, which ranges from a continuous transmission to 120 minutes.

2.1 STATUS DATA CONNECTIONS

1. Connect the transmitting device to any input (DIGITAL INPUT), so that you get a status change in the input, i.e. +12 V "ON or OFF". You can take the plus voltage from the power supply + -screw or from the separate + -output.

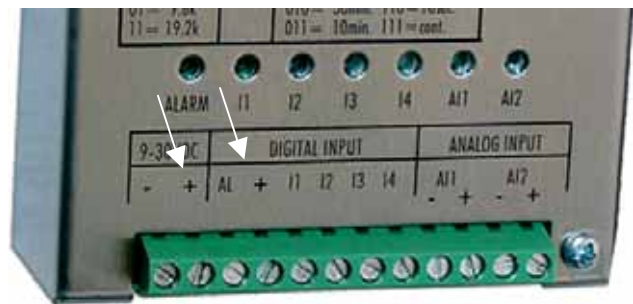

2. Connect the corresponding output of receiving I-LINK 100 to the device you want to control.

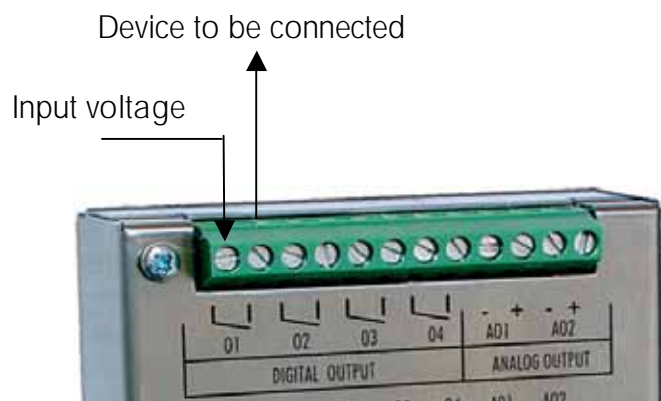

2.2 ANALOG CONNECTIONS

1. Analog sensors and gauges should be connected to their own + and - inputs and outputs. Notice that sensors need their own supply voltage, mentioned separately in connection with the delivery of the sensor.

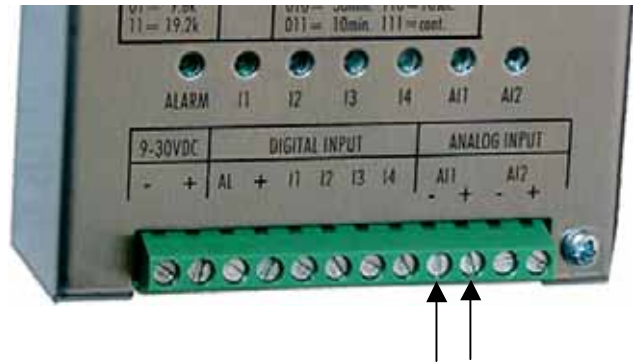

Analog inputs

2. Choose the analogue sensor transmission sequence with the TIME settings.

For more information concerning the functions of the I-LINK 100, see the I-LINK 100 User Guide in the M2M package.

CONNECTION EXAMPLES

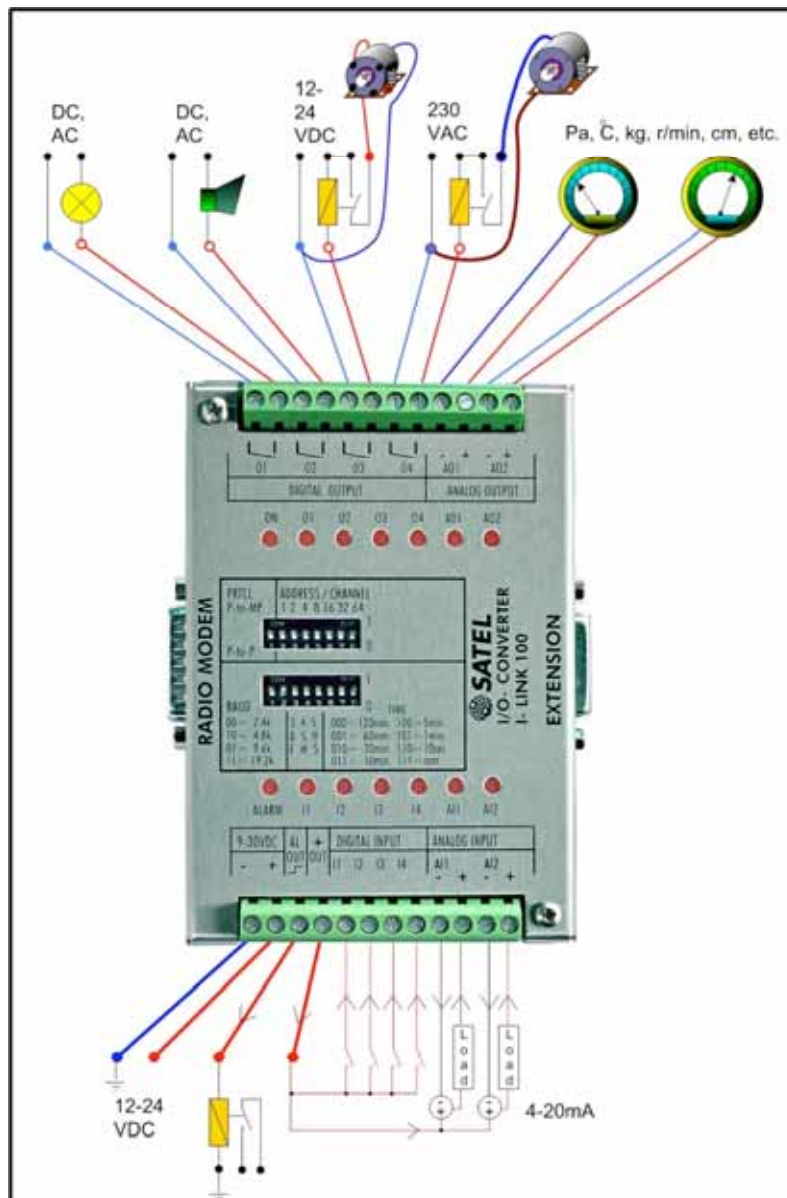

3 CHANNEL CHANGE GENERAL

The radio modems of the M2M-package operate on the European license free frequency band. This band has several different channels. Sometimes it may happen that few systems use the same channel. If this occurs, the system stability may change and behave in an uncertain manner. However, if this happens, it is possible to change the radio modems to another channel.

The standard M2M sales package is pre-set to a specific channel and changes are not needed in order to start the normal operation. The changes are needed only, if the system doesn't work properly.

3.1 How to change the channel in Point-to-Point operation

When the power is turned ON, the I-LINK 100 reads the channel information from the ADDRESS switches 1-2-4-8. In default mode the setting is 0-0-0-0.

The channel can be changed by turning first the power OFF and then by setting the ADDRESS switches (channel selector) to other position for example 1-0-0-0. 1 = up / 0 = down.

Channel numbering: 0001 = ch1,
0010 = ch2, 0011 = ch3, 0100 = ch4,
0101 = ch5, 0110 = ch6, 0111 = ch7, 1000 = ch8, 1001 = ch9, 1010 = ch10.

The channel must be the same for both I-LINK 100 units before turning power ON. When the power is ON the operation channel has changed.

NOTE1! 0000 = disable.

NOTE2! The I-LINK 100 unit will not operate with the settings 1011, 1100, 1101, 1110 or 1111. The power ON indicator starts to blink in case any of these settings has been chosen.

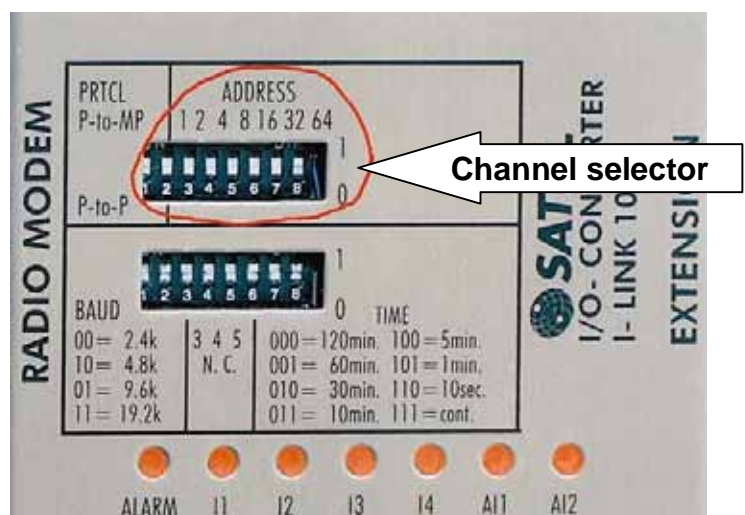



SATEL OY

Meriniitynkatu 17, P.O. Box 142

24101 Salo, FINLAND

Tel: +358 2 777 7800

Fax: +358 2 777 7810

E-mail info@satel.fi

www.satel.fi