



Appendixes to AT Commands Interface Guide for 6.57 Release

Revision: 004
Date: November 2006



wavocom[®]
Make it wireless

Appendixes to AT Commands Interface Guide for 6.57 Release

Reference: WM_ASW_OAT_UGD_00044

Revision: 004

Date: November 3, 2006

Trademarks

®, WAVECOM®, WISMO® and Open AT® and certain other trademarks and logos appearing on this document, are filed or registered trademarks of Wavecom S.A. in France or in other countries. All other company and/or product names mentioned may be filed or registered trademarks of their respective owners.

Copyright

This manual is copyrighted by WAVECOM with all rights reserved. No part of this manual may be reproduced in any form without the prior written permission of WAVECOM.

No patent liability is assumed with respect to the use of the information contained herein.

Appendixes to AT Commands Interface Guide for 6.57 Release

Overview

This document contains the technical appendixes for AT Commands Interface Guide for 6.57 document, second release (file WM_ASW_OAT_UGD_00044-004.pdf). This is the second release of the document for this software revision and also indicates the general AT commands.

Appendices to AT Commands Interface Guide for 6.57 Release

Document History

Revision	Date	History of the evolution	
001	25 th April 2004	First edition for X55 AT software	
003	February 23, 2006	Update for X56 release:	
004	November 3, 2006	Update	

Appendixes to AT Commands Interface Guide for 6.57 Release

Contents

1	CODES AND VALUES	7
1.1	ME error result code: +CME ERROR	7
1.2	Message service failure result code: +CMS ERROR	9
1.3	Specific error result codes.....	9
1.4	Failure Cause from GSM 04.08 recommendation (+CEER).....	11
1.5	Specific Failure Cause for +CEER.....	13
1.6	GSM 04.11 Annex E-2: Mobile originating SM-transfer.....	14
1.7	Unsolicited result codes.....	16
1.8	Final result codes.....	17
1.9	Intermediate result codes	18
1.10	Parameters storage.....	18
1.11	GSM sequences list.....	24
1.12	Operator names.....	26
1.13	CPHS Information field	27
1.14	CSP constants	28
2	EXAMPLES	32
2.1	Examples with the PIN required.....	32
2.2	Examples where a voice call is originated.....	33
2.3	Example with incoming calls	34
2.4	Example of a call forwarding	35
2.5	Example of a multiparty call.....	36
2.6	Examples about phonebooks	37
2.7	Examples about short messages	44
2.8	Examples about Fax class 2.....	45
2.9	+CSIM and +CRSM Examples.....	47
2.10	+WBHV Examples	49

Appendixes to AT Commands Interface Guide for 6.57 Release

3	TECHNICAL APPENDIXES	53
3.1	Data / Commands multiplexing protocol	53
3.2	Multiplexing mode.....	56
3.3	Support of SIM ToolKit by the M.E.	65
3.4	Structure of TERMINAL PROFILE	66
3.5	Command Type and Next Action Indicator.	70
3.6	Coding of Alpha fields in the SIM for UCS2.....	71
3.7	Specifications of Power down Control mechanism through serial Ports (physical ⇔ RS232 ports or virtual ⇔ CMUX ports)	73
3.8	Description of Multi-Flow behavior	79
4	COMMAND EXECUTION AND DEPENDENCE TO SIM.....	82
4.1	General commands.....	82
4.2	Call Control commands	83
4.3	Network service commands	83
4.4	Security commands.....	84
4.5	Phonebook commands	84
4.6	Short Messages commands	84
4.7	Supplementary Services commands	85
4.8	Data commands	86
4.9	Fax commands.....	86
4.10	Class 2 Commands.....	86
4.11	V24-V25 commands.....	87
4.12	Specific AT commands	87
4.13	SIM Toolkit commands.....	88
4.14	GPRS commands.....	89
5	INTEROPERABILITY	90

Appendixes to AT Commands Interface Guide for 6.57 Release

1 Codes and values

1.1 ME error result code: +CME ERROR

<error> is defined as below:

<error>	Meaning	Resulting from the following commands
3	Operation not allowed	All GSM 07.07 commands (+CME ERROR: 3)
4	Operation not supported	All GSM 07.07 commands (+CME ERROR: 4)
5	PH-SIM PIN required (SIM lock)	All GSM 07.07 commands (+CME ERROR: 5)
10	SIM not inserted	All GSM 07.07 commands (+CME ERROR: 10)
11	SIM PIN required	All GSM 07.07 commands (+CME ERROR: 11)
12	SIM PUK required	All GSM 07.07 commands (+CME ERROR: 12)
13	SIM failure	All GSM 07.07 commands (+CME ERROR: 13)
16	Incorrect password	+CACM, +CAMP, +CPUC, +CLCK, +CPWD, +CPIN, +CPIN2 (+CME ERROR: 16)
17	SIM PIN2 required	+CPBW (FDN), +CLCK (FDN),
18	SIM PUK2 required	+CACM, +CAMP, +CPUC, +CPBW (FDN), +CPIN, +CPIN2, +CLCK (FDN), +CPWD
20	Memory full	+CPBW, +WOLM
21	Invalid index	+CPBR, +CPBW, ATD>[mem]index, +WMGO, +WPGW, +WOLM
22	Not found	+CPBF, +CPBP, +CPBN, +CGSN, +WOPN, ATD>[mem]"name"
24	Text string too long	+CPBW, +CPIN, +CPIN2, +CLCK, +CPWD, +WPGW, +WCCS, +WIMEI
26	Dial string too long	+CPBW, ATD, +CCFC
27	Invalid characters in dial string	+CPBW
30	No network service	+VTS, +COPS=?, +CLCK, +CCFC, +CCWA, +CUSD
32	Network not allowed – emergency calls only	+COPS
40	Network personalization PIN required (Network lock)	All GSM 07.07 commands (+CME ERROR: 40)
42	Network personalization PIN required (Network subset lock)	All GSM 07.07 commands (+CME ERROR: 42)
44	Network personalization PIN required (Service Provider lock)	All GSM 07.07 commands (+CME ERROR: 44)
46	Network personalization PIN required (Corporate lock)	All GSM 07.07 commands (+CME ERROR: 46)
103	Incorrect MS identity.	+CGATT

Appendixes to AT Commands Interface Guide for 6.57 Release

<error>	Meaning	Resulting from the following commands
106	ME is blacklisted by the network.	+CGATT
107	MS is not allowed to operate in GPRS.	+CGATT
111	MS is not allowed to operate in the requested PLMN.	+CGATT
112	MS is not allowed to make location updating in this area.	+CGATT
113	Roaming in this location area is not allowed.	+CGATT
132	service option not supported (#32)	+CGACT +CGDATA ATD*99
133	requested service option not subscribed (#33)	+CGACT +CGDATA ATD*99
134	service option temporarily out of order (#34)	+CGACT +CGDATA ATD*99
148	unspecified GPRS error	All GPRS commands
149	PDP authentication failure	+CGACT +CGDATA ATD*99
150	invalid mobile class	+CGCLASS +CGATT

Appendixes to AT Commands Interface Guide for 6.57 Release

1.2 Message service failure result code: +CMS ERROR

<er> is defined as below:

<er>	Meaning	Resulting from the following commands
1 to 127	Error cause values from the GSM recommendation 04.11 Annex E-2	+CMGS, +CMSS
301	SMS service of ME reserved	+CSMS (with +CMS: ERROR 301)
302	Operation not allowed	All SMS commands (+CMSS, +CMGL, +CPMS, +CSMP...
303	Operation not supported	All SMS commands
304	Invalid PDU mode parameter	+CMGS, +CMGW
305	Invalid text mode parameter	+CMGS, +CMGW, +CMSS
310	SIM not inserted	All SMS commands
311	SIM PIN required	All SMS commands
312	PH-SIM PIN required	All SMS commands
313	SIM failure	All SMS commands
316	SIM PUK required	All SMS commands
317	SIM PIN2 required	All SMS commands
318	SIM PUK2 required	All SMS commands
321	Invalid memory index	+CMGR, +CMSS, +CMGD
322	SIM or ME memory full	+CMGW
330	SC address unknown	+CSCA?, +CMSS, +CMGS
340	no +CNMA acknowledgement expected	+CNMA

1.3 Specific error result codes

<error>	Meaning	Resulting from the following commands
500	unknown error.	All commands
512	MM establishment failure (for SMS).	+CMGS, +CMSS (+CMS ERROR: 512)
513	Lower layer failure (for SMS)	+CMGS, +CMSS (+CMS ERROR: 513)
514	CP error (for SMS).	+CMGS, +CMSS (+CMS ERROR: 514)
515	Please wait, init or command processing in progress.	All commands (" +CME ERROR: 515" or "+CMS ERROR: 515") except ATH0, ATH1, AT+WIOR, AT+WIOW, AT+CFUN=1, AT+CLCC, AT+WAC, AT+CPAS, AT+VGR, AT+VTS, AT+SPEAKER.
517	SIM Toolkit facility not supported.	+STGI

Appendixes to AT Commands Interface Guide for 6.57 Release

<error>	Meaning	Resulting from the following commands
518	SIM Toolkit indication not received.	+STGI
519	Reset the product to activate or change a new echo cancellation algorithm.	+ECHO, +VIP
520	Automatic abort about get PLMN list for an incoming call.	+COPS=?
526	PIN deactivation forbidden with this SIM card.	+CLCK
527	Please wait, RR or MM is busy. Retry your selection later.	+COPS
528	Location update failure. Emergency calls only.	+COPS
529	PLMN selection failure. Emergency calls only.	+COPS
531	SMS not sent: the <da> is not in FDN phonebook, and FDN lock is enabled. (for SMS)	+CMGS, +CMSS (+CMS ERROR: 531)
532	the embedded application is activated so the objects flash are not erased	+WOPEN
533	Missing or Unknown APN	ATD*99 +GACT +CGDATA
536	Class locked: a command has been launched from a port, the effect is to lock all commands belonging to the same class. If another port launches a command of this class, this error will occur as long as the class is not released (at first command's completion time)	All commands
537	Phonebook group full.	+CPBW
538	Not Enough Space to copy SMS	+WMCP
539	Invalid SMS	+CMGR
541	Open AT® application and AT software version do not match	+WOPEN
543	CMUX connection is refused by remote, after a restart of CMUX protocol by modem , due to a 27.010 connection loss during virtual channels establishment.	+CMUX
544	CMUX connection Timeout (no answer from the remote) ie no DLC0 opened response.	+CMUX
545	A CMUX session has been started on a physical UART, and user tries to start another CMUX session on other physical UART. The error, <i>+CME ERROR: 545</i> is raised on the UART where <i>at+cmux</i> command is trying to be started again.	+CMUX

Appendixes to AT Commands Interface Guide for 6.57 Release

<error>	Meaning	Resulting from the following commands
546	Emergency call is not allowed without SIM	+COPS
547	Emergency call is allowed without SIM	+COPS
548	No flash objects to delete	+WOPEN
549	The phone number of the requested phonebook entry is empty	ATD><index>[:], ATD><phonebook><index>[:]
550	Unable to resize the Application & Data storage place, since the new required size would overlap with the current Open AT application storage place.	+WOPEN
551	Service abort request has failed	AT +WAC
552	Unsolicited responses for autodiag or charge indications are already activated on another port	+WDIAG, +WBCM

1.4 Failure Cause from GSM 04.08 recommendation (+CEER)

Cause value	Diagnostic
1	Unassigned (unallocated) number
3	No route to destination
6	Channel unacceptable
8	Operator determined barring
16	Normal call clearing
17	User busy
18	No user responding
19	User alerting, no answer
21	Call rejected
22	Number changed
26	Non selected user clearing
27	Destination out of order
28	Invalid number format (incomplete number)
29	Facility rejected
30	Response to STATUS ENQUIRY
31	Normal, unspecified
34	No circuit/channel available
38	Network out of order
41	Temporary failure

Appendixes to AT Commands Interface Guide for 6.57 Release

Cause value	Diagnostic
42	Switching equipment congestion
43	Access information discarded
44	Requested circuit/channel not available
47	Resources unavailable, unspecified
49	Quality of service unavailable
50	Requested facility not subscribed
55	Incoming calls barred with in the CUG
57	Bearer capability not authorized
58	Bearer capability not presently available
63	Service or option not available, unspecified
65	Bearer service not implemented
68	ACM equal to or greater than ACMmax
69	Requested facility not implemented
70	Only restricted digital information bearer capability is available
79	Service or option not implemented, unspecified
81	Invalid transaction identifier value
87	User not member of CUG
88	Incompatible destination
91	Invalid transit network selection
95	Semantically incorrect message
96	Invalid mandatory information
97	Message type non-existent or not implemented
98	Message type not compatible with protocol state
99	Information element non-existent or not implemented
100	Conditional IE error
101	Message not compatible with protocol state
102	Recovery on timer expiry
111	Protocol error, unspecified
127	Inter-working, unspecified
224	MS requested detach
225	NWK requested Detach
226	Unsuccessful attach cause NO SERVICE
227	Unsuccessful attach cause NO ACCESS
228	Unsuccessful attach cause GPRS SERVICE REFUSED
229	PDP Deactivation requested by NWK

Appendixes to AT Commands Interface Guide for 6.57 Release

Cause value	Diagnostic
230	PDP Deactivation because LLC link activation Failed
231	PDP Deactivation cause NWK reactivation with same TI
232	PDP Deactivation cause GMM abort
233	PDP Deactivation cause LLC or SMDCP failure
234	PDP Unsuccessful activation cause GMM error
235	PDP Unsuccessful activation cause NWK reject
236	PDP Unsuccessful activation cause NO NSAPI available
237	PDP Unsuccessful activation cause SM refuse
238	PDP Unsuccessful activation cause MMI ignore
239	PDP unsuccessful activation cause Nb Max Session Reach

All other values in the range	will be treated as cause
[0,31]	31
[32,47]	47
[48,63]	63
[64,79]	79
[80,95]	95
[96,111]	111
[112,127]	127

1.5 Specific Failure Cause for +CEER

Cause value	Diagnostic
240	FDN is active and number is not in FDN
241	Call operation not allowed
252	Call barring on outgoing calls
253	Call barring on incoming calls
254	Call impossible
255	Lower layer failure

Appendixes to AT Commands Interface Guide for 6.57 Release

1.6 GSM 04.11 Annex E-2: Mobile originating SM-transfer

These error causes could appear for **SMS commands** (+CMGS, +CMSS, +CMGD...)

Error #	Error label	Description
1	Unassigned (unallocated) number	The destination requested by the Mobile Station cannot be reached because, although the number is in a valid format, it is not currently assigned (allocated).
8	Operator determined barring	The MS has tried to send a mobile originating short message when the MS's network operator or service provider has forbidden such transactions.
10	Call barred	The outgoing call barred service applies to the short message service for the called destination.
21	Short message transfer rejected	The equipment sending this cause does not wish to accept this short message, although it could have accepted the short message since the equipment sending. This cause is neither busy nor incompatible.
27	Destination out of service	The destination indicated by the Mobile Station cannot be reached because the interface to the destination is not functioning correctly. The term "not functioning correctly" indicates that a signaling message was unable to be delivered to the remote user; e.g., a physical layer or data link layer failure at the remote user, user equipment off-line, etc.
28	Unidentified subscriber	The subscriber is not registered in the PLMN (e.g.. IMSI not known)
29	Facility rejected	The facility requested by the Mobile Station is not supported by the PLMN.
30	Unknown subscriber	The subscriber is not registered in the HLR (e.g.. IMSI or directory number is not allocated to a subscriber).
38	Network out of order	The network is not functioning correctly and the condition is likely to last a relatively long period of time; e.g., immediately reattempting the short message transfer is not likely to be successful.
41	Temporary failure	The network is not functioning correctly and the condition is not likely to last a long period of time; e.g., the Mobile Station may wish to try another short message transfer attempt almost immediately.
42	Congestion	The short message service cannot be serviced because of high traffic.
47	Resources unavailable, unspecified	This cause is used to report a resource unavailable event only when no other cause applies.
50	Requested facility not subscribed	The requested short message service could not be provided by the network because the user has not completed the necessary administrative arrangements with its supporting networks.

Appendixes to AT Commands Interface Guide for 6.57 Release

Error #	Error label	Description
69	Requested facility not implemented	The network is unable to provide the requested short message service.
81	Invalid short message transfer reference value	The equipment sending this cause has received a message with a short message reference which is not currently in use on the MS-network interface.
95	Invalid message, unspecified	This cause is used to report an invalid message event only when no other cause in the invalid message class applies.
96	Invalid mandatory information	The equipment sending this cause has received a message where a mandatory information element is missing and/or has a content error (both cases are undistinguishable).
97	Message type non-existent or not implemented	The equipment sending this cause has received a message with a message type it does not recognize either because this is a message not defined or defined but not implemented by the equipment sending this cause.
98	Message not compatible with short message protocol state	The equipment sending this cause has received a message such that the procedures do not indicate that this is a permissible message to receive while in the short message transfer state.
99	Information element non-existent or not implemented	The equipment sending this cause has received a message which includes unrecognized information elements because the information element identifier is not defined or it is defined but not implemented by the equipment sending the cause. However, the information element is not required to be present in the message so that the equipment sends the cause to process the message.
111	Protocol error, unspecified	This cause is used to report a protocol error event only when no other cause applies.
127	Inter-working, unspecified	There has been inter-working with a network which does not provide causes for actions it takes; thus, the precise cause for a message which is being sent cannot be ascertained.

All values other than specified should be treated as error #41.

Appendixes to AT Commands Interface Guide for 6.57 Release

1.7 Unsolicited result codes

Verbose result code	Numeric (VO set)	Description
+CALA: < time string>,<index>	As verbose	Alarm notification
+CBM: <length><pdu> (PDU) or +CBM:<sn>,<mid>,<dcs>,<page>,<pages>... (Text mode)	As verbose	Cell Broadcast Message directly displayed
+CBMI: "BM",<index>	As verbose	Cell Broadcast Message stored in mem at location <index>
+CCCM: <ccm>	As verbose	Current Call Meter value
+CCED: <values>	As verbose (specific)	Cell Environment Description indication
+CCWA:<number>,<type>,<class> [,<alpha>]	As verbose	Call Waiting number
+CDS: <fo>,<mr>... (text mode) or +CDS: <length>,... (PDU)	As verbose	SMS status report after sending a SMS
+CDSI: <mem>,<index>	As verbose	Incoming SMS Status Report after sending a SMS, stored in <mem> ("SR") at location <index>
+CKEV: <keynb>	As verbose	Key press or release
+CLIP: <number>,<type> [,,,<alpha>]	As verbose	Incoming Call Presentation
+CMT: <oa>... (text mode) or +CMT: [<alpha>,...] (PDU)	As verbose	Incoming message directly displayed
+CMTI: <mem>,<index>	as verbose	Incoming message stored in <mem> ("SM") at location <index>
+CREG: <stat>[,<lac>,<ci>]	As verbose	Network registration indication
+CRING: <type>	As verbose	Incoming call type (VOICE, FAX ...)
+CSQ: <RxLev>,99	As verbose	Automatic RxLev indication with AT+CCED=1,8 command
+CSSU: <code2>[<number>,<type>]	As verbose	Supplementary service notification during a call
+STIN: <ind>	As verbose (specific)	SIM Toolkit Indication
+WIND: <IndicationNb> [,<CallId>]	As verbose (specific)	Specific unsolicited indication (SIM Insert/Remove, End of init, Reset, Alerting, Call creation/release)
+WVMI: <Lineld>,<Status>	As verbose (specific)	Voice Mail Indicator notification (cf. +CPHS command)

Appendixes to AT Commands Interface Guide for 6.57 Release

Verbose result code	Numeric (VO set)	Description
+WDCI: <Lineld>,<Status>	As verbose (specific)	Diverted call indicator
RING	2	Incoming call signal from network
+WBCI	As Verbose (specific)	Battery charge indication
+CIEV	As Verbose (specific)	Indicator event reporting
+CUSD: <m>,[<str>,<dcs>]	As verbose	USSD unsolicited response

1.8 Final result codes

Verbose result code	Numeric (VO set)	Description
+CME ERROR: <err>	As verbose	Error from GSM 07.05 commands
+CMS ERROR: <err>	As verbose	Error from SMS commands (07.07)
BUSY	7	Busy signal detected
ERROR	4	Command not accepted
NO ANSWER	8	Connection completion timeout
NO CARRIER	3	Connection terminated
OK	0	Acknowledges correct execution of a command line
RING	2	Incoming call signal from network

Appendixes to AT Commands Interface Guide for 6.57 Release

1.9 Intermediate result codes

Verbose result code	Numeric (V0 set)	Description
+COLP:<number>,<type>	as verbose	Outgoing Call Presentation
+CR: <type>	as verbose	Outgoing Call report control
+ILRR: <rate>	as verbose	Local TA-TE data rate
CONNECT 300	10	Data connection at 300 bauds
CONNECT 1200	11	Data connection at 1200 bauds
CONNECT 1200/75	12	Data connection at 1200/75 bauds
CONNECT 2400	13	Data connection at 2400 bauds
CONNECT 4800	14	Data connection at 4800 bauds
CONNECT 9600	15	Data connection at 9600 bauds
CONNECT 14400	16	Data connection at 14400 bauds
+CSSI: <code1>[,<index>]	As verbose	Supplementary service notification during a call setup

1.10 Parameters storage

Command	Parameters storage mode				Default values
	AT&W (E2P)	Command (E2P)	AT+CSAS (SIM, E2P)	AT&F (SIM, E2P)	
General commands					
+CMEE	X			X	0
+CRSL		X		X	6
+CSCS	X			X	"PCCP437"
+WPCS	X			X	"TRANSPARENT"

Appendixes to AT Commands Interface Guide for 6.57 Release

Parameters storage mode					
Command	AT&W (E2P)	Command (E2P)	AT+CSAS (SIM, E2P)	AT&F (SIM, E2P)	Default values
Call Control commands					
%D		X		X	0
ATSO	X			X	0 (no auto-answer)
+CICB	X			X	2 (speech)
+CSNS	X			X	0 (voice)
+ECHO		X		X	For Wireless CPU 2 and 3 ,1,0,3,10,7 (Algo ID 1) ,3,30,8000,256 (Algo ID 3) For Wireless CPU 5: ,3,30,8000,256 (Algo ID 3)
+SIDET	X			X	1,2
+SPEAKER	X			X	0 (Speaker 1 & Micro 1)
+VGR	X			X	128 (speaker 1) 32 (speaker 2)
+VGT	X			X	32 (mic 1 & ctrl 1) 0 (others)
Network Service commands					
+COPS	X	X		X	0,2
+CREG	X			X	0
Phonebook commands					
+CSVM		X		X	0
+WAIP	X			X	0
+WCOS		X			0

Appendixes to AT Commands Interface Guide for 6.57 Release

Command	Parameters storage mode			AT&F (SIM, E2P)	Default values
	AT&W (E2P)	Command (E2P)	AT+CSAS (SIM, E2P)		
SMS commands					
+CNMI			X	X	0,1,0,0,0
+CMGF	X			X	1 (text)
+CMMS					0
+CSCA			X		SIM dependant (phase 2)
+CSDH	X			X	0
+CSMP			X	X	1,167,0,0
+CSMS		X			0
+WUSS		X		X	0
Supplementary Services commands					
+CCUG		X			0,0,0
+CCWA	X			X	0
+CLIP	X			X	0
+COLP	X			X	0
+CSSN	X			X	0,0
+CUSD		X		X	0
Data commands					
%C	X			X	0
\N	X			X	0
+CBST	X			X	0,0,1
+CR	X			X	0
+CRC	X			X	0
+CRLP	X			X	61,61,48,6,1
+DOPT	X			X	1,1
+DS	X			X	3,0,2048,20
+DR	X			X	0
+ILRR	X			X	0

Appendixes to AT Commands Interface Guide for 6.57 Release

Parameters storage mode					
Command	AT&W (E2P)	Command (E2P)	AT+CSAS (SIM, E2P)	AT&F (SIM, E2P)	Default values
Fax Class 2 commands					
+FBOR	X			X	0
+FCQ	X			X	0
+FCR	X			X	1
+FDCC,+FDIS	X			X	0,5,0,0,2,0,0,0,0
+FPHCTO	X			X	30
V24 - V25 commands					
&C	X				1
&D	X				2
&S	X				1
E	X				1
Q	X			X	0
V	X			X	1
+ICF	X				3,4
+IFC	X				2,2
+IPR	X				115200
+WMUX	X			X	0

Appendixes to AT Commands Interface Guide for 6.57 Release

Parameters storage mode					
Command	AT&W (E2P)	Command (E2P)	AT+CSAS (SIM, E2P)	AT&F (SIM, E2P)	Default values
Specific commands					
+ADC		X		X	0
+CMER	X			X	,0,,0
+CPHS		X		X	1,0 for VMI 2,0 for MBN 4,0 for DCI
+WBCM		X		X	0,0,4200,3400,100,5000,0
AT+WBHV		X		X	Parameter2=0
For param1=0		X		X	Parameter2=0
For param1=1		X		X	Parameter2=0
For param1=2		X		X	Parameter2=0
For param1=3		X		X	Parameter2=0
+WBM		X			for SPI bus: 0,0 for I2C Soft bus : For Quick Q2xx3 For Quick Q2xx3 Pin Names Pac P3xx3 Pin Names Q24X6 Pin Names Q24 Classic, Q24 Plus, Q24 Extended and Q24 Auto Pac P32X6 Pin Names Pac P51x6 Pin Names 0,4 For Quirk Q31x6 Pin Names 3,4 For Quick Q25xx Pin Names 5,9
+WCCS		X			CUSTOM table is the same as PCCP437 to GSM table.
+WCDM		X		X	0,0
+WCDP		X		X	0
+WDR		X			0,1
+WDIAG		X		X	Type → 0 freq → 0 trig1 → 0 trig2 → 0 trig3 → 0 trig3_freq → 0
+WIND		X		X	0

Appendixes to AT Commands Interface Guide for 6.57 Release

Parameters storage mode

Command	AT&W (E2P)	Command (E2P)	AT+CSAS (SIM, E2P)	AT&F (SIM, E2P)	Default values
+WIOM		X			1023,0 (for Q2xxx Q24 Classic, Q24 Plus, Q24 Extended and Q24 Auto and P3xxx) 0,0 (for Q31 and P51 Wireless CPUs)
+WRIM		X		X	0
+WSVG		X		X	0
+WVR		X			5,0
+WMFM		X			+WMFM: 0,2,1,1 +WMFM: 0,2,2,0 +WMFM: 1,2,4,0 +WMFM: 1,2,4,1

SIM Toolkit commands					
+STSF		X			0,"1F6BFFFF1F",3,1

GPRS commands					
+CGAUTO	X			X	3
+CGCLASS		X			"B"
+CGDCONT		x			
+CGEREP	X			X	0
+CGREG	X			X	0
+CGSMS		X			1
+WGPRS		X			0,1 1,0 3,0 5,0 6,0

Appendixes to AT Commands Interface Guide for 6.57 Release

1.11 GSM sequences list

In accordance with **GSM 02.30**, the product supports the following GSM sequences, which can be used through the ATD and the +CKPD commands.

1.11.1 Security

Change PIN code	**04* <i>OLDPIN</i> * <i>NEWPIN</i> * <i>NEWPIN</i> #
Change PIN2 code	**042* <i>OLDPIN2</i> * <i>NEWPIN2</i> * <i>NEWPIN2</i> #
Unlock PIN code	**05* <i>PUK</i> * <i>NEWPIN</i> * <i>NEWPIN</i> #
Unlock PIN2 code	**052* <i>PUK2</i> * <i>NEWPIN2</i> * <i>NEWPIN2</i> #
Show the IMEI number	*#06#

1.11.2 Call forwarding

Please refer to SC and BS values below in this paragraph.

Activate <i>or</i>	*SC# *SC**BS#
Register and activate <i>or</i> <i>or</i> <i>or</i> <i>or</i> <i>or</i>	**SC* <i>PhoneNumber</i> # **SC* <i>PhoneNumber</i> *BS# **SC* <i>PhoneNumber</i> *[BS]*T# *SC* <i>PhoneNumber</i> # *SC* <i>PhoneNumber</i> *BS# *SC* <i>PhoneNumber</i> *[BS]*T#
Check status <i>or</i>	*#SC# *#SC**BS#
Deactivate <i>or</i>	#SC# #SC**BS#
Unregister and deactivate <i>or</i>	##SC# ##SC**BS#

Appendixes to AT Commands Interface Guide for 6.57 Release

Service Codes (SC)	
002	all call forwarding
004	all conditional call forwarding
21	call forwarding unconditional
61	call forwarding on no answer
62	call forwarding on not reachable
67	call busy

Network Service Codes (BS)	
<i>No code</i>	All tele and bearer services
10	All tele-services
11	Telephony
12	All data tele-services
13	Fax services
16	Short Message Services
17	Voice Group Call Service
18	Voice Broadcast Service
19	All tele-services except SMS
20	All bearer services
21	All asynchronous services
22	All synchronous services
24	All data circuit synchronous
25	All data circuit asynchronous

Note: The no-reply condition timer (T), is only used for SC = 002, 004 or 61.

1.11.3 Call barring

Please refer to SC values below in this paragraph. BS values are the same as above, see §1.11.2.

Activate <i>or</i>	*SC*Password# *SC*Password*BS#
Check status <i>or</i>	**SC# **SC**BS#
Deactivate <i>or</i>	#SC*Password# #SC*Password*BS#
Change password for call barring <i>or</i> <i>or</i> <i>or</i>	**03*330*OLDPWD*NEWPWD*NEWPWD# **03**OLDPWD*NEWPWD*NEWPWD# *03*330*OLDPWD*NEWPWD*NEWPWD# *03**OLDPWD*NEWPWD*NEWPWD#

Appendixes to AT Commands Interface Guide for 6.57 Release

Service Codes (SC)	
33	call barring of outgoing call
330	all barring service (only for deactivation)
331	call barring of outgoing international call
332	call barring of outgoing international calls except to HPLMN
333	all outgoing barring service (only for deactivation)
35	call barring of incoming calls
351	call barring of incoming calls if roaming
353	all incoming barring service (only for deactivation)

1.11.4 Call waiting

BS values are the same as above, see §1.11.2.

Activate	*43*BS#
Check status	*#43*BS#
Deactivate	#43*BS#

1.11.5 Number presentation

CLIP check status	*#30#
CLIR check status	*#31#
Suppress CLIR for a voice call	*31# <i>PhoneNumber</i>
Invoke CLIR for a voice call	#31# <i>PhoneNumber</i>
COLP check status	*#76#

1.12 Operator names

Refer to the following documentation:

- SE13 (22nd August,2005)
- NAPRD10 2.6.8

Appendixes to AT Commands Interface Guide for 6.57 Release

1.13 CPHS Information field

CPHS Information		
Data field	Bit Field	Meaning
0	None	All information
1	0	CSP service activated and allocated
2	1	SST service activated and allocated
3	2	Mailbox Number service activated and allocated
4	3	Operator Name Shortform service activated and allocated
5	4	Information Numbers service activated and allocated
6	5	RFU
7	6	RFU
8	7	RFU
9	8	Voice Message Waiting indicator for Line 1
10	9	Voice Message Waiting indicator for Line 2
11	10	Data Message Waiting indicator
12	11	Fax Message Waiting indicator
13	12	Call Forward Activated indicator for Line 1
14	13	Call Forward Activated indicator for Line 2
15	14	Call Forward Activated indicator for Data
16	15	Call Forward Activated indicator for Fax
17	16	Reserved
18	17	Reserved
19	18	Reserved
20	19	Reserved
21	20	Line 1 Mailbox Number available
22	21	Line 2 Mailbox Number available
23	22	Data Mailbox Number available
24	23	Fax Mailbox Number available
25	24	EF Mn Updateable

Appendixes to AT Commands Interface Guide for 6.57 Release

1.14 CSP constants

1.14.1 Service Group: Call Offering

Service	External value
Call Forwarding Unconditional	1
Call Forwarding On User Busy	2
Call Forwarding on No Reply	3
Call Forwarding On User Not Reachable	4
Call Transfer	5

1.14.2 Service Group: Call Restriction

Service	External value
Barring of All Outgoing Calls	9
Barring of Outgoing International Calls	10
Barring of Outgoing International Calls except those directed to the Home PLMN country	11
Barring of All Incoming Calls when Roaming Outside the Home PLMN country	12
BIC roam	13

1.14.3 Service Group: Other Supplementary Services

Service	External value
Multi-Party Service	17
Closed User Group	18
Advice Of Charge	19
Preferential CUG	20
CUG Outgoing Access	21

Appendixes to AT Commands Interface Guide for 6.57 Release

1.14.4 Service Group: Group Completion

Service	External value
Call Hold	25
Call Waiting	26
Completion of Call to Busy Subscriber	27
Restriction of the menus allowing use of user to user signaling	28

1.14.5 Service Group: Teleservices

Service	External value
Short Message – Mobile Terminated	33
Short Message – Mobile Originated	34
Short Message – Cell Broadcast	35
Restricts menu options for the ability to set reply path active on outgoing Short Messages	36
SMS Delivery Confirmation	37
Restriction of menus for SMS Protocol ID options	38
Validity Period, restriction of menus for SMS Validity period options	39

1.14.6 Service Group: CPHS Teleservices

Service	External value
Alternate Line Service	41

1.14.7 Service Group: CPHS Features

Service	External value
Reserved: SST in phase 1 CPHS	49

Appendixes to AT Commands Interface Guide for 6.57 Release

1.14.8 Service Group: Number Identification

Service	External value
Calling Line Identification Presentation	57
Connected Line Identification Restriction	59
Connected Line Identification Presentation	60
Malicious Call Indicator	61
CLI per call mode - default block CLI - menu to send CLI	63
CLI per call mode - default send CLI - menu to block CLI	64

1.14.9 Service Group: Phase 2+ Services

Service	External value
Menus concerned with GPRS functionality	65
Menus concerned with High Speed Circuit Switched Data functionality	66
ASCI Voice Group call menus	67
ASCI Voice Broadcast service menus	68
Multi Subscriber profile menus	69
Multiple band: Restriction of menus allowing user to select a particular GSM 900/ 1800 or 1900 band	70

Appendixes to AT Commands Interface Guide for 6.57 Release

1.14.10 Service Group: Value Added Services

Service	External value
Restriction of menu options for manual PLMN selection	73
Restriction of menu options for Voice Mail or other similar menus	74
Restriction of menu options for the ability to send Short messages with type Paging	75
Restriction of menu options for the ability to send Short messages with type Email	76
Restriction of menu options for Fax calls	77
Restriction of menu options for Data calls	78
Restriction of menus allowing the user to change language	80

1.14.11 Service Group: Information Numbers

Service	External value
The ME shall only present Information numbers to the user if this field is set to FF	81

Note: External values not used in these tables are reserved for further use.

Appendixes to AT Commands Interface Guide for 6.57 Release

2 Examples

This chapter gives illustrative examples of the general AT commands used for a communication. The presentation of commands and responses is as close as possible to what a user can see on its test monitor. Blank lines have been intentionally removed. The characters on the left margin are DTE generated. Middle column characters are modem generated.

2.1 Examples with the PIN required

2.1.1 when the ME has to be powered ON

```
AT+CMEE=1           Enable the report mobile equipment errors
  OK
AT+CREG=1           Report registration
  OK
AT+CPAS             Query ME Status
  +CPAS: 5         (ME is asleep)
  OK
AT+CFUN=1           Set ME to full functionality
  OK
AT+COPS=0           Ask for automatic operator selection and registration.
  +CME ERROR: 11  SIM PIN required.
AT+CPIN=1234        User entered a wrong PIN
  +CME ERROR: 16  Incorrect password.
AT+CPIN=0000
  OK               PIN Ok
AT+COPS=0           Ask for automatic operator selection and registration.
  OK
  +CREG:1          Registered on the network
AT+COPS=3,0        Select the long name alphanumeric format.
  OK
AT+COPS?           Get the operator name
  +COPS: 0,0,"I OMNITEL"
  OK
```

Appendixes to AT Commands Interface Guide for 6.57 Release

2.1.2 When the ME has already been powered on

AT+CMEE=1 *Enable the report mobile equipment errors*
OK
AT+CPAS *Get the ME Status*
+CPAS: 0 *ME is ready to receive commands*
OK
AT+CPIN? *Is ME requiring a password?*
+CPIN: SIM PIN *Yes, SIM PIN required*
AT+CPIN=0000
OK *PIN Ok*

2.2 Examples where a voice call is originated

2.2.1 When the ME is powered on and the SIM PIN has been entered

AT+CMEE=1 *Enable the reporting of mobile equipment errors*
OK
AT+WIND=63 *Ask to display the general indications.*
OK
AT+CPIN? *Is ME requiring a password?*
+CPIN: READY *product is ready*
ATD0607103543; *Make a voice call*
+WIND: 5,1 *Indication of call*
+WIND: 2 *Remote party is ringing.*
OK *Call setup was successful*
Conversation...
ATH *Release the call*
OK

2.2.2 When a voice call is attempted from a phonebook

ATD>"John Pamborn";
+CME ERROR: 22 *The "John Pamborn" entry is not found.*
ATD>"Joel Guerry";
+WIND: 5,1 *Indication of outgoing call.*
+WIND: 2 *Remote party is ringing.*
OK *Call setup was successful*
Conversation...
ATH *Release the call*
OK

Appendixes to AT Commands Interface Guide for 6.57 Release

2.3 Example with incoming calls

2.3.1 When the ME is powered on and the SIM PIN has been entered

AT+CMEE=1 *Enable the report mobile equipment errors*
OK

AT+WIND=63 *Ask to display the general indications.*
OK

AT+CLIP=1 *Enable the calling line identification presentation.*
OK

AT+CRC=1 *Enable extended format of incoming indication.*
OK

AT+CNUM *Query own number (voice number) or MSISDN.*
+CNUM: "Speech", "+33608971019", 145
OK

Call this number from another equipment.

+WIND: 5, 1 *Indication of call (Ring)*

+CRING: VOICE *Type of call is VOICE.*

+CLIP: "+33607103543", 145, "", "John Panborn" *Identification of the remote party.*

+CRING: VOICE

ATA *Answer the call.*
OK

...Conversation...

NO CARRIER *The call has been released by the remote party.*

+WIND: 6, 1 *Indication of call release.*

Appendixes to AT Commands Interface Guide for 6.57 Release

2.4 Example of a call forwarding

2.4.1 When the ME is powered on and the SIM PIN has been entered

AT+CMEE=1	<i>Enable the report mobile equipment errors</i>
OK	
AT+CCFC=1,3,"0607492638"	<i>Register to a call forwarding when ME is busy.</i>
OK	
AT+CCFC=2,3,"0149293031",129	<i>Register to a call forwarding when it does answer.</i>
+CME ERROR: 30	<i>No network service</i>
AT+CCFC=1,2	<i>Interrogate</i>
+CCFC: 1,1,"+33607492638",145	<i>Call forwarding active for a voice call.</i>
AT+CCFC=1,4	<i>Delete call forwarding ME busy</i>
OK	

Appendixes to AT Commands Interface Guide for 6.57 Release

2.5 Example of a multiparty call

When the ME is powered on and the SIM PIN has been entered.

```
AT+CMEE=1          Enable the report mobile equipment errors
    OK
AT+WIND=63         Ask to display the general indications.
    OK
AT+CCWA=1,1       Enable call waiting.
    OK
ATD>"John Panborn";
    +WIND: 5,1      Indication of call.
    +WIND: 2        Remote party is ringing.
    OK             Call setup was successful
...Conversation (call1)...
    +WIND: 5,2      Indication of another call.
    +CCWA: "+33595984834",145,"Dolores Claiborne" Another call is waiting.
AT+CHLD=2         Put first call on hold and answer the second one.
    OK
...Conversation (call2)...
AT+CHLD=3         Every call is part of a multiparty conversation.
    OK
AT+CHLD=11        Release the first call (with John Panborn) and recover the second call (with Dolores Claiborne)
...Conversation (call2)...
ATH              Release the second call.
```

Appendixes to AT Commands Interface Guide for 6.57 Release

2.6 Examples about phonebooks

For each example illustrated in this section: at the beginning the ME is powered on and the SIM PIN has been entered.

2.6.1 Example 1: The whole phonebook of the ME is read

Command	Response
AT+CPBS=? <i>Note: Query supported phonebook memories</i>	+CPBS: ("SM","FD","ON") <i>Note: ADN, FDN, and MSISDN phonebooks supported.</i>
AT+CPBS="SM" <i>Note: Select ADN phonebook.</i>	OK
AT+CPBR=? <i>Note: Read the index range and the length of the elements.</i>	+CPBR: (1-80),20,14 OK <i>Note: 80 locations (from 1 to 80), max length of 20 for the phone number, 14 characters max for the text.</i>
AT+CPBR=1,80 <i>Note: Read all entries (only the set ones are returned).</i>	+CPBR: 1,"0346572834",129,"Dolores Claiborne" +CPBR: 2,"1284374523",129,"Thad Beaumont" +CPBR: 3, "1243657845",129,"John Panborn" OK

2.6.2 Example 2: Erase or Write a phonebook entry

Command	Response
AT+CPBW=? <i>Note: Get the phonebook type.</i>	+CPBW: (1-80),20,(129,145),14 <i>Note: 80 locations, max length of 20 for the phone number, TON/NPI of 129 or 145 and 14 characters max for the text.</i>
AT+CPBW=3 <i>Note: Erase location 3</i>	OK
AT+CPBW=3,"4356729012",129,"Carry" <i>Note: Write at location 3.</i>	OK
AT+CPBR=1,80 <i>Note: Read all entries (only the ones set are returned).</i>	+CPBR: 1,"0346572834",129,"Dolores Claiborne" +CPBR: 2,"1284374523",129,"Thad Beaumont" +CPBR: 3,"4356729012",129,"Carry" OK

Appendixes to AT Commands Interface Guide for 6.57 Release

2.6.3 Example 3: Find phonebook entries

Command	Response
AT+CPBF=? <i>Note: Get the phonebook type.</i>	+CPBF: 20,14 <i>Note: Max length of 20 for the phone number, 10 characters for the text.</i>
AT+CPBF="D" <i>Note: Read entries starting with "D".</i>	+CPBF: 1,"0346572834",129,"Dolores Clairborne" OK
AT+CPBF="W" <i>Note: Read entries with "W".</i>	+CME ERROR: 22 <i>Note: Entry not found.</i>

2.6.4 Example 4: Phonebook and custom character set

The Custom To Extended GSM conversion table and the Extended GSM To Custom conversion table can be used to display the extended GSM characters:

| ^ € { } [] ~ \

To manage one of these extended characters, the character 0x1B must be set in the right place (in the position corresponding to the value of the ASCII code) in the Custom to GSM conversion table (instead of 0x20 (space ASCII code)).

For example, the ASCII code of \ (backslash) is 0x5C, the character 0x1B must be set at the position 0x5C of the Custom to GSM conversion table. The range of character 0x5C in this table is 92. So to update the table the command AT+WCCS=1,0,92 will be used.

In the other way, write the space ASCII code 0x20 in the right place in the Custom to GSM conversion table if an extended character is not needed.

Command	Response
AT+CPBS? <i>Note: Query the current phonebook</i>	+CPBS: 3,80 OK <i>Note: ADN selected, 3 entries stored</i>
AT+WPCS? <i>Note: Query the current phonebook char set</i>	+WPCS: "TRANSPARENT" OK <i>Note: Transparent mode selected</i>
AT+CPBR=1	+CPBR: 1,"0146290800",129,"S bastien" OK <i>Note: GSM character "é" is not displayed</i>

Appendixes to AT Commands Interface Guide for 6.57 Release

Command	Response
AT+WCCS=1,0,0,255 >2020202020202020200A20200D2020202020 20205F2020202020202020202021222302252 62728292A2B2C2D2E2F30313233343536373839 3A3B3C3D3E3F004142434445464748494A4B4C 4D4E4F505152535455565758595A20202020112 06162636465666768696A6B6C6D6E6F70717273 7475767778797A20202020202020202020202 0202020202020202027272020202020202020 20202020204020012403205F20202020202D2 0202020202720202020202020202020604141 41415B0E1C09451F454549494949445D4F4F4F4 F5C200B5555555E59201E7F6161617B0F1D6304 05656507696969207D086F6F6F7C200C0675757 E792079	OK
AT+WCCS=1,1,0,127 >40A324A5E8E9F9ECF2C70AD8F80DC5E5205F2 0202020202020202020C6E6DFC920212223A425 262728292A2B2C2D2E2F3031323334353637383 93A3B3C3D3E3FA14142434445464748494A4B4 C4D4E4F505152535455565758595AC4D6D1DCA 7BF6162636465666768696A6B6C6D6E6F707172 737475767778797AE4F6F1FCE0 <i>Note: Set the custom character set tables to enable a GSM to default font conversion</i>	OK
AT+WPCS="CUSTOM" <i>Note: Use the custom character set</i>	OK
AT+CPBR=1	+CPBR: 1,"0146290800",129,"Sébastien" OK <i>Note: GSM character "é" is correctly displayed</i>

Appendixes to AT Commands Interface Guide for 6.57 Release

2.6.5 Example 5: Use the extended phonebook

Command	Response
AT+WCOS?	+WCOS: 0 OK <i>Note: Phonebook not extended</i>
AT+CPBS?	+CPBS: "SM",10,20 OK <i>Note: Selected phonebook: ADN</i>
AT+CPBW=1,"0123456",,"test"	OK <i>Note: Write an entry in SIM</i>
AT+CPBR=1	+CPBR: 1,"0123456",129,"test" OK <i>Note: Read an entry in SIM</i>
AT+CPBW=1,"0123456",,"test",1	+CME ERROR: 3 <i>Note: +WCOS=0; you can't write a phonebook group</i>
AT+WCOS=1	OK <i>Note: Phonebook extended in SIM</i>
AT+CPBW=1,"0123456",,"test",1	OK <i>Note: Write an entry in SIM</i>
AT+CPBR=1	+CPBR: 1, "0123456", 129, "test", 1 OK <i>Note: Read an entry in SIM (extended)</i>
AT+WCOS=0	OK
AT+WCOS?	+WCOS: 0 OK <i>Note: Phonebook not extended</i>
AT+CPBR=1	+CPBR: 1,"0123456",129,"test" OK <i>Note: Read an entry in SIM (not extended)</i>
AT+CPBS="ME"	OK <i>Note: Selected phonebook: ME (Flash)</i>
AT+WCOS=1	OK <i>Note: Phonebook extended</i>

Appendixes to AT Commands Interface Guide for 6.57 Release

Command	Response
AT+CPBW=1, "+331290909", 145, "Fred", "0141284549", 129, "0600003210", 129, "0141280000", 129, "019876543210", 129, "fred@mywebaddress.com", "Becker Street London",1	OK <i>Note: Write an entry in Flash</i>
AT+CPBR=1	+CPBR: 1, "+331290909", 145,"Fred", "0141284549", 129, "0600003210", 129, "0141280000", 129, "019876543210", 129, "fred@mywebaddress.com", "Becker Street London",1 OK
AT+WCOS=0	OK
AT+CPBR=1	+CPBR: 13,"+331290909",145,"Fred" OK <i>Note: Read an entry in Flash (not extended)</i>

To use the extended ME phonebook, you must do:

AT+CPBS="ME"

AT+WCOS=1

To use the extended ADN phonebook, you must do:

AT+CPBS="SM"

AT+WCOS=1

To use the not extended phonebook, you must do:

AT+WCOS=0

2.6.6 Example 6: Phonebook and custom character set

Command	Response
AT+CPBS? <i>Note: Query the current phonebook</i>	+CPBS: 3,80 OK <i>Note: ADN selected, 3 entries stored</i>
AT+WPCS? <i>Note: Query for the current phonebook character set</i>	+WPCS: "TRANSPARENT" OK <i>Note: Transparent mode selected</i>
AT+CPBW=1,"0146290800",129,"test of { }"	

Appendixes to AT Commands Interface Guide for 6.57 Release

Command	Response
AT+CPBR=1	+CPBR: 1,"0146290800",129," test of " OK <i>Note: GSM characters "{" and "}" are not displayed</i>
AT+WCCS=1,0,0,255<CR> >2020202020202020200A20200D2020202020 20205F2020202020202020202021222302252 62728292A2B2C2D2E2F30313233343536373839 3A3B3C3D3E3F004142434445464748494A4B4C 4D4E4F505152535455565758595A1B1B1B1B11 206162636465666768696A6B6C6D6E6F7071727 37475767778797A1B1B1B1B201B20202020202 02020202020202020202727202020202020 2020202020204020012403205F20202020202 D202020202027202020202020202020206041 4141415B0E1C09451F4545494949445D4F4F4 F4F5C200B5555555E59201E7F6161617B0F1D63 0405656507696969207D086F6F6F7C200C06757 57E792079 <CTRL-Z>	OK
AT+WCCS=1,1,0,127<CR> >40A324A5E8E9F9ECF2C70AD8F80DC5E5205F2 0202020202020202020C6E6DFC920212223A425 262728292A2B2C2D2E2F3031323334353637383 93A3B3C3D3E3FA14142434445464748494A4B4 C4D4E4F505152535455565758595AC4D6D1DCA 7BF6162636465666768696A6B6C6D6E6F707172 737475767778797AE4F6F1FCE0 <CTRL-Z> <i>Note: Set the custom character set tables to enable a GSM to default font conversion</i>	OK
AT+WPCS="CUSTOM" <i>Note: Use the custom character set</i>	OK
AT+CPBR=1	+CPBR: 1,"0146290800",129," test of { }" OK <i>Note: GSM characters "{" and "}" are correctly displayed</i>

Appendixes to AT Commands Interface Guide for 6.57 Release

2.6.7 Example 7: MT Phonebook (read only)

Command	Response
AT+CPBS="MT"	OK <i>Note: Select MT phonebook</i>
AT+WCOS=1 <i>Note: Select extended entries</i>	OK
AT+CPBF="" <i>Note: Read all entries</i>	+CPBF: 1,"0987654321",129,"Carry",0 +CPBF: 2;"9876543210",129,"John",0 +CPBF: 31,"0346572834",129,"Dolores Claiborne","9876543210",129,"","","6547891230",129 ,"dolores@mywebaddress.com","Becker Street London",0 +CPBF: 32,"6547892012",129,"Pierre",,"", ,"","9874521021",129,"","",,"Pierre@mywebaddress.com ","",0 OK
AT+WCOS=0 <i>Note: Select extended entries: not extended</i>	OK
AT+CPBF="" <i>Note: Read all entries</i>	+CPBF: 1,"0987654321",129,"Carry" +CPBF: 2;"9876543210",129,"John" +CPBF: 31,"0346572834",129,"Dolores Claiborne" +CPBF: 32,"6547892012",129,"Pierre" OK

Index: 1 and 2 → SM phonebook entries

Index: 31 and 32 → ME phonebook entries

Appendixes to AT Commands Interface Guide for 6.57 Release

2.7 Examples about short messages

2.7.1 Send a short message

AT+CNMI=0,1,1,1,0 *SMS-DELIVERs are directly stored, SMS-STATUS-REPORTs are displayed*
OK

AT+CSMP=17,169,0,0 *SMS-SUBMIT message with a validity period (one day)*
OK

AT+CMGF=1 *Text mode to send a Short Message*
OK

AT+CSCA="+33608080706" *Set Service Center Address to +33608080706*
OK

AT+CMGS=0601290800 *Send a SMS-SUBMIT to mobile phone*
Product sends a 4 characters sequence: 0x0D 0x0A 0x3E 0x20

This is the first text line *Edit first line and press carriage return (<CR>, 0x0D)*

This is the last text line *Edit last line and send message by pressing <ctrl-Z> (0x1A)*

+CMGS: 5 *Success: message reference 5 is returned from the SMS Service Center*

+CDS: 2,5,"0601290800",129,"99/05/01 14:15:10+04"

Success: report of successful message delivery received

2.7.2 Read short messages

AT+CMGF=1 *Text mode to read Short Messages*

AT+CMGL="ALL" *List all stored messages*

+CMGL: 1,"REC READ","+336290918",,"99/05/01 14:15:10+04"

I will be late *This is the first message*

+CMGL: 2,"REC UNREAD","+336290918",,"99/05/01 14:19:44+04"

Traffic jam on Broadway *This is the second message*

OK

AT+CMGR=1 *Read the first message*

+CMGR: "REC READ","+336290918",,"99/05/01 14:19:44+04"

OK

Appendixes to AT Commands Interface Guide for 6.57 Release

2.8 Examples about Fax class 2

2.8.1 Send a fax class 2

```
AT+FCLASS=2          Select fax class 2
OK
AT+FLID="LocalFax"
OK
ATD0601234567       Call establishment
+FCON               Connection OK
[+FCSI: "RemoteFax"]
+FDIS:0,3,0,2,0,0,0
OK
AT+FDT              Beginning of the data transfer
+FDCS:0,3,0,2,0,0,0
CONNECT
<0x11h>             Send carrier
First page data terminated by <0x10h><0x03h>
OK                  Page transmitted
AT+FET=0            Send another page
+FPTS:1             First page acquitted
OK
AT+FDT
CONNECT
<0x11h>             Send carrier
Second page data terminated by <0x10h><0x03h>
OK                  Page transmitted
AT+FET=2            No more page
+FPTS:1             First page acknowledged
+FHNG:0            Normal end of connection
OK
```

Appendixes to AT Commands Interface Guide for 6.57 Release

2.8.2 Receive a fax class 2

```
AT+FCR=1
    OK
AT+FLID="LocalFax"
    OK
    RING                Incoming call
ATA                Answer
+FCON                Connection OK
    [+FTSI: "RemoteFax"]
    +FDCS:0,3,0,2,0,0,0,0
    OK
AT+FDR
    +FCFR
    +FDCS:0,3,0,2,0,0,0,0
    CONNECT
    <0x12h>                Receive page carrier
    First page data terminated by
    <0x10h><0x03h>
    OK                Page received
+FPTS:1                First page acknowledged
+FET:0                To receive another page
    OK
AT+FDR
    +FDCS:0,3,0,2,0,0,0,0
    CONNECT
    <0x12h>                Receive page carrier
    Second page data terminated by
    <0x10h><0x03h>
    OK                Page received
    +FPTS:1                Second page acknowledged
+FET:2                No more page to receive
    OK
AT+FDR
    +FHNG:0                Normal end of connection
    OK
```

Appendixes to AT Commands Interface Guide for 6.57 Release

2.9 +CSIM and +CRSM Examples

NOTE: if SIM answer is not specified in the following examples, it will mean that the answer will depend on the SIM content.

2.9.1 DF GSM selection and then status

```
AT+CSIM=14,"A0A40000027F20"  
+CSIM=4,"9F16"  
AT+CSIM=10,"A0F2000016"  
+CSIM=48,"..."
```

2.9.2 DF Telecom selection and then status

```
AT+CSIM=14,"A0A40000027F10"  
+CSIM=4,"9F16"  
AT+CSIM=10,"A0F2000016"  
+CSIM=48,"..."
```

2.9.3 EF ADN selection and then status

DF Telecom selection is mandatory just before the following AT commands.

```
AT+CSIM=14,"A0A40000026F3A"  
+CSIM=4,"9F0F"  
AT+CSIM=10,"A0C000000F"  
+CSIM=34,"..."
```

Appendixes to AT Commands Interface Guide for 6.57 Release

2.9.4 Status commands

Status - No File Id - without P1, P2, P3

AT+CRSM=242

Status - 6F3A (EF ADN) - without P1, P2, P3

AT+CRSM=242,28474

Status - 6F07 (EF IMSI) - without P1, P2, P3

AT+CRSM=242,28423

Status - 3F00 (MF) - without P1, P2, P3

AT+CRSM=242,16128

Status - 7F10 (DF Telecom) - without P1, P2, P3

AT+CRSM=242,32528

Status - 7F20 (DF GSM) - without P1, P2, P3

AT+CRSM=242,32544

2.9.5 Get Response commands

Get Response - (EF ADN) - without P1, P2, P3

AT+CRSM=192,28474

Get Response - (EF IMSI) - without P1, P2, P3

AT+CRSM=192, 28423

Get Response - (MF) - without P1, P2, P3

AT+CRSM=192,16128

Get Response - (DF Telecom) - without P1, P2, P3

AT+CRSM=192,32528

Get Response - (DF GSM) - without P1, P2, P3

AT+CRSM=192,32544

Get Response - 6F07 (EF IMSI)

AT+CRSM=192, 28423,0,0,15

2.9.6 Read Record commands

Read Record - EF ADN (Pin Code validated)

AT+CRSM=178,28474,1,4,28

Appendixes to AT Commands Interface Guide for 6.57 Release

2.10 +WBHV Examples

2.10.1 Restart the Wireless CPU

```
AT+CFUN=1  
OK
```

2.10.2 Interrogate modem configuration

```
AT+WBHV?  
+WBHV: 0,0  
+WBHV: 1,0  
+WBHV: 2,0  
+WBHV: 3,0,0  
OK
```

2.10.3 Activate ENS feature (there is no STK session open yet)

```
AT+WBHV=3,1  
+CME ERROR: 3
```

2.10.4 Open a STK session

```
AT+STSF=2,"5FFFFFFF7F"  
OK  
AT+STSF=1  
OK
```

2.10.5 Activate ENS feature

```
AT+WBHV=3,1  
OK
```

```
AT+WBHV=3  
+WBHV: 3,1,1 // Wireless CPU reset is needed  
OK
```

Appendixes to AT Commands Interface Guide for 6.57 Release

2.10.6 Restart the Wireless CPU and interrogate ENS feature mode

AT+CFUN=1

OK

AT+WBHV=3

+WBHV: 3,1,0

OK

2.10.7 Deactivate ENS feature

AT+WBHV=3,0

OK

AT+WBHV=3

+WBHV: 3,0,1 // Wireless CPU reset is needed

OK

2.10.8 Restart the Wireless CPU and interrogate modem ENS feature mode

AT+CFUN=1

OK

AT+WBHV=3

+WBHV: 3,0,0 // Wireless CPU reset is not needed

OK

2.10.9 Activate and deactivate the feature

AT+WBHV=3,1

OK

AT+WBHV=3

+WBHV: 3,1,1 // Wireless CPU reset is needed

OK

Appendixes to AT Commands Interface Guide for 6.57 Release

AT+WBHV=3,0

OK

AT+WBHV=3

+WBHV: 3,0,0 // Wireless CPU reset is not needed

OK

2.10.10 Restore factory settings

Case 1: ENS feature is already deactivated

AT+WBHV=3

+WBHV: 3,0,0 // Wireless CPU reset is not needed

OK

AT&F

OK

AT+WBHV=3

+WBHV: 3,0,0 // Wireless CPU reset is not needed

OK

Activate the ENS feature

AT+WBHV=3,1

OK

AT+WBHV=3

+WBHV: 3,1,1 // Wireless CPU reset is needed

OK

AT&F // restore the factory settings again

OK

AT+WBHV=3

+WBHV: 3,0,0 // Wireless CPU reset is not needed for the new setting

OK

Appendixes to AT Commands Interface Guide for 6.57 Release

Case 2: ENS feature is already activated

AT+WBHV=3

+WBHV: 3,1,0 // *Wireless CPU reset is not needed*

OK

AT&F

OK

AT+WBHV=3

+WBHV: 3,0,1 // *Wireless CPU reset is needed for the new setting*

OK // *since the ENS feature mode before AT&F is '1'*

3 Technical appendixes

3.1 Data / Commands multiplexing protocol

3.1.1 Introduction

The Wavecom multiplexing protocol operates between a DCE (Data Communication Equipment: the product) and a DTE (Data Terminal Equipment). It allows a double session over a serial link interface: one for AT commands and one for DATA communications.

AT+WMUX=1 activates the Multiplexing Mode. With this mode, AT commands and DATA are encapsulated into packets. The header of these packets allows to recognize whether it is a DATA packet or an AT command packet. AT+WMUX=0 deactivates the Multiplexing Mode and gets the product back to the default mode.

This appendix presents how the multiplexing mode handles the DATA and the AT commands flow. It also describes the format of DATA packets and AT command packets.

3.1.2 AT command packets

An AT command is encapsulated into a packet with a header which allows to separate it from DATA packets. This packet is formed by a header (3 bytes), the AT command itself and a checksum (1 byte):

Appendixes to AT Commands Interface Guide for 6.57 Release

B7	B6	B5	B4	B3	B2	B1	B0
Start pattern ^ 0xAA							
AT command length LSB							
AT command pattern ^ 0x1D					AT command length MSB		
AT command							
Checksum							

The 3 bytes of the header are:

- the first byte (0xAA) is used to identify the packet,
- the second byte represents the 8 LSB (Low Significant Bits) bits of the length of the AT command,
- the third byte is made of 2 parts:
 - the 3 LSB bits are the 3 MSB (Most Significant Bits) bits of the length of the AT command,
 - the 5 MSB bits (0x1D which equals to 0xE8 with the 3 bits offset) are used to identify an AT command.

The maximum length of an AT command could be 2047 bytes which is greater than all the existing AT commands.

The checksum is the addition (modulo 256) of all the transmitted bytes (header bytes and AT command bytes).

3.1.3 Data packets

Like for AT commands, DATA are encapsulated into packets. These packets are composed of a header (3 bytes), the data bytes and the checksum (1 byte):

B7	B6	B5	B4	B3	B2	B1	B0
Start pattern ^ 0xDD							
Data packet length LSB							
Data packet type					Data packet length MSB		
Data Bytes							
Checksum							

The 3 bytes of the header are:

- the first byte (0xDD) used to identify the packet,
- the second byte represents the 8 LSB bits of the length of the data field,
- the last byte is made of 2 parts:
 - the 3 LSB bits represent the 3 MSB bits of the length of the data field,

Appendixes to AT Commands Interface Guide for 6.57 Release

- the 5 MSB bits represent the packet type.

Data packets can have different values according to the type of packet:

- ➔ 0 – DATA packet: the packet contains the data to transmit on the radio link or received from the radio link,
- ➔ 1 – STATUS packet: the packet contains the status of SA, SB, X bits⁽¹⁾ and the break condition coding as follow:

SA	SB	X	BRK	RI	Spare	Spare	Spare
----	----	---	-----	----	-------	-------	-------

- the length of data for the status packet is always equal to 1,
- whenever a status changes (except break), all the status bits are included,
- these bits are off by default (and therefore the bits DTR and RTS), so it is necessary to send a status packet to the target at the beginning of the multiplexing to start the transmission,
- ➔ 2 – READY packet: the packet indicates that the target is ready to receive data:
 - no data are transmitted in this packet (so the length is null),
- ➔ 3 – BUSY packet: the packet indicates that the target is busy and can not receive data:
 - like the ready packet, no data are transmitted,
- ➔ other values: currently, these values are not used (reserved for future enhancement).

The checksum is calculated like the AT command packet checksum (addition of all the transmitted bytes including the header bytes).

3.1.4 Example: AT command and its answer

When there is no encapsulation the AT command transmitted on the serial link is like this (in ASCII and hexadecimal):

`AT\r\n` ⇔ `0x41 0x54 0x0D 0x0A`

and the answer is like this:

`\r\nOK\r\n` ⇔ `0x0D 0x0A 0x4F 0x4B 0x0D 0x0A`

With the encapsulation in the serial link, the packet transmitted is (in hexadecimal):

`0xAA 0x04 0xE8 0x41 0x54 0x0D 0x0A 0x42`

¹ These status bits contain the V24 control information:

- SA contains DTR (signal CT108 – from terminal to IWF) and DSR (signal CT107 – from terminal to IWF),
- SB contains RTS (signal CT105 – from terminal to IWF) and DCD (signal CT109 – from IWF to terminal),
- X contains CTS (signal CT106).

For more information, refer to GSM 07.02

Appendixes to AT Commands Interface Guide for 6.57 Release

and the answer is like this:

0xAA 0x06 0xE8 0x0D 0x0A 0x4F 0x4B 0x0D 0x0A 0x60

3.1.5 Example: Initialization and Data packet

When the Multiplexing Mode is activated (+WMUX=1), the product sends 2 Data packets after the establishment of a DATA call (after the CONNECT xxxx message): 1 READY Packet and 1 STATUS Packet. To set the different signals to the right value, it is necessary to send a STATUS packet to the product.

Here are some examples of STATUS packets:

0xDD 0x01 0x08 0x40 0x26 ⇔ bit RTS is on

to start a data call, all the bits should be on:

0xDD 0x01 0x08 0xC0 0xA6 ⇔ bits DTR and RTS are on

3.1.6 Restriction

The autobauding mode is not available when the Multiplexing Mode is activated: the serial link speed must be set to a fixed rate.

3.2 Multiplexing mode

3.2.1 Description

The AT+CMUX command is used to manage (enable or disable) the 3GPP TS 27.010 multiplexing protocol control channel. It allows to multiplex up to 4 logical channels on a single UART. Two UARTS are available on WAVECOM Wireless CPUs, but multiplexing can apply to only one. The client application may handle, by this mean, up to 5 channels (4 logical multiplexed channels on a UART, and 1 physical channel on the other UART).

Notes on speed and autobauding:

- The response is returned at the speed of the received AT+CMUX command (prior to entering <mode>).
- It is recommended that whenever the multiplexer control channel is released, the modem should assume an interface rate for autobauding purposes irrespective of any previous higher speed having been selected.
- If a +CMUX command is issued whilst in any multiplexer mode then that +CMUX command is ignored and the modem will return an +CME ERROR: <err> response.

Appendixes to AT Commands Interface Guide for 6.57 Release

3.2.1.1 Restrictions

- Only basic option and UIH framing is supported.
- Only convergence layers type 1 and 3 are supported.
- Autobauding is not compatible with multiplex mode. It is neither possible to start multiplexing when autobauding is active (AT+IPR=0), nor to set autobauding during multiplex mode, since the multiplexer uses only a fixed baudrate. In the same way, the bit rate can not be changed through AT+IPR command while multiplex mode is active. Therefore, AT+IPR=<rate> should not be used, and will have no effect.

3.2.1.2 Specific behaviors

- In multiplex mode, AT configuration commands (as AT+CMEE for example), (see : [2]§ 1.10) will be applied to all logical channels.
- In multiplex mode, unsolicited result code (see : [2]§ 1.7) will be transmitted to all logical channels
- AT commands are grouped by classes (SMS, phonebook, GRPS, SIM TOOL KIT, ... See [2] §3.7.1) and launching an AT command from a port, has for the effect to lock all commands belonging to the same class.
If another port launches an AT command of the locked class, an +CME ERROR: 536 will occur as long as the class is not released (at first command's completion time).
- If GPS is used in internal mode in UART2, it is not possible to start MUX on UART2. In the same way, if MUX is started on UART2, it is not possible to use GPS in internal mode.
- If Bluetooth is started, it is not possible to start CMUX on UART2. In the same way, if MUX is started on UART2, it is not possible to start Bluetooth.
- If TMT (Terminal Emulator) is launched on a specific UART, it is not possible to start MUX on this UART. TMT must be first close on this UART. On the opposite, as soon as CMUX is started, HAPC can be started on a DLCi.
- After an *at+cfun=1* during a CMUX session, CMUX is automatically restarted by the modem with previous parameters, and all previous opened DLCs are reopened, with the speed of *at+ipr?* command.
- DCD, RI and DTR signals are managed virtually:
When V24 sets DCD,RI or DTR signal, a MSC frame is sent to remote part, to indicate a virtual state change. Everything is logical, no physical signals are involved.
- +++ Escape Sequence is always possible to get offline.
- Flow control is managed physically or virtually by MSC.
By default, Wireless CPU manages a hardware flow control on a UART, and this flow control becomes virtual on logical channels when some DLCs are opened.

Appendixes to AT Commands Interface Guide for 6.57 Release

- At CMUX session stop, WAVECOM Wireless CPU automatically goes back into AT mode, without having to reset the Wireless CPU.
- Two timeouts are implemented for CMUX connection :
 - CMUX start connection : 30 seconds.
After this timeout, MUX is closed, and previous physical port is reopened.
 - DLC inactivity timeouts : 5 minutes.
This timeout is armed only if no DLC are opened, to avoid to be blocked into only DLC0 opening channel state. After this timeout, MUX is closed, and previous physical port is reopened.

3.2.2 Results

AT+CMUX=<mode>[,<subset>[,<port_speed>[,<N1>[,<T1>[,<N2>[,<T2>[,<T3>]]]]]]]
, will respond OK when parameters are in the range, and number of parameters are in correct syntax.

AT+CMUX=<mode>[,<subset>[,<port_speed>[,<N1>[,<T1>[,<N2>[,<T2>[,<T3>]]]]]]]
, will respond ERROR when :

ERROR Responses	Meaning
+CME ERROR: 3	<ul style="list-style-type: none"> ✓ Operation not allowed: <i>Example:</i> Trying to start a MUX session during autobauding. ✓ Parameters or number of parameters are out of range. <i>Example:</i> Parameter <i><port_speed>=8</i>
+CME ERROR: 543	CMUX connection is refused by remote, after a restart of CMUX protocol by modem , due to a 27.010 connection loss during virtual channels establishment.
+CME ERROR: 544	CMUX connection Timeout (no answer from the remote) ie no DLC0 opened response.
+CME ERROR: 545	A CMUX session has been started on a physical UART, and user tries to start another CMUX session on other physical UART. The error, <i>+CME ERROR: 545</i> is raised on the UART where <i>at+cmux</i> command is trying to be started again.

Appendixes to AT Commands Interface Guide for 6.57 Release

3.2.3 Execution conditions

Before reception of errors of §2.1, AT+CMUX=<mode>[,<subset>[,<port_speed>[,<N1>[,<T1>[,<N2>[,<T2>[,<T3>]]]]]] first reply OK.

3.2.4 Power down control (Sleep mode)

CMUX feature is based on ETSI 27.010 specifications that provide Sleep-On/Wake-Up procedure through 27.010 multiplexing protocol. It suits the description of the serial port sleep mode mechanism (Please refer to §3.7 Specifications of Power down Control mechanism through serial Ports (physical ⇔ RS232 ports or virtual ⇔ CMUX ports)).

To match sleep mode specifications (as specified in §3.7.4), WAVECOM Wireless CPU handles 27.010 MSC protocol frames that are dependent of each emulated port (associated to a particular DLCI).

⇔ **Physical signals (such as DTR)** of the UART on which it has been activated **are not monitored** by WAVECOM Wireless CPU (DCE)

To cope with WAVECOM sleep mode, 27.010 sleep mode procedures are authorized only when all activated emulated/virtual ports are in Serial Sleep mode state ⇔ emulated application DTR and CTS are low on each port, no AT response is to be sent.

CMUX wake-up/sleep-on frames as specified in 27.010 recommendations applies to all activated DLC since those particular frames (PSC frames) are sent/received over the DLCI 0, which is the control channel.

3.2.5 Sleep mode activation

For all opened DLCI, each connected application on each DLC should set its DTR low in order to have the Wireless CPU sleep.

Appendixes to AT Commands Interface Guide for 6.57 Release

DTR (DTE e.g. logical MSC frame through PC MUX driver)

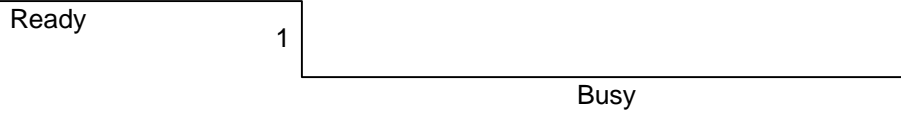

CTS (DTE e.g. logical MSC frame sent by the WAVECOM module)

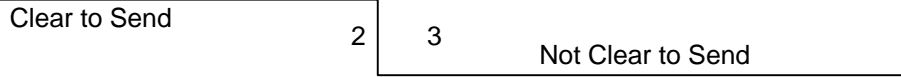

RX data line (DTE)

- 1: The application (DTE) drops DTR to indicate a busy state (a protocol MSC frame is sent by the PC CMUX driver on the concerned DLCI)
- 2: WAVECOM Wireless CPU (DCE) checks if there are any pending AT response to send.
- 3: When DTR is low and there are no more AT responses, the DCE sets CTS to low.

Once the last opened DLCI detects the DTR drop from the PC application, the CMUX driver starts sending a 27.010 PSC protocol frame, and waits for its response before allowing the entire system to go into Sleep Mode state.

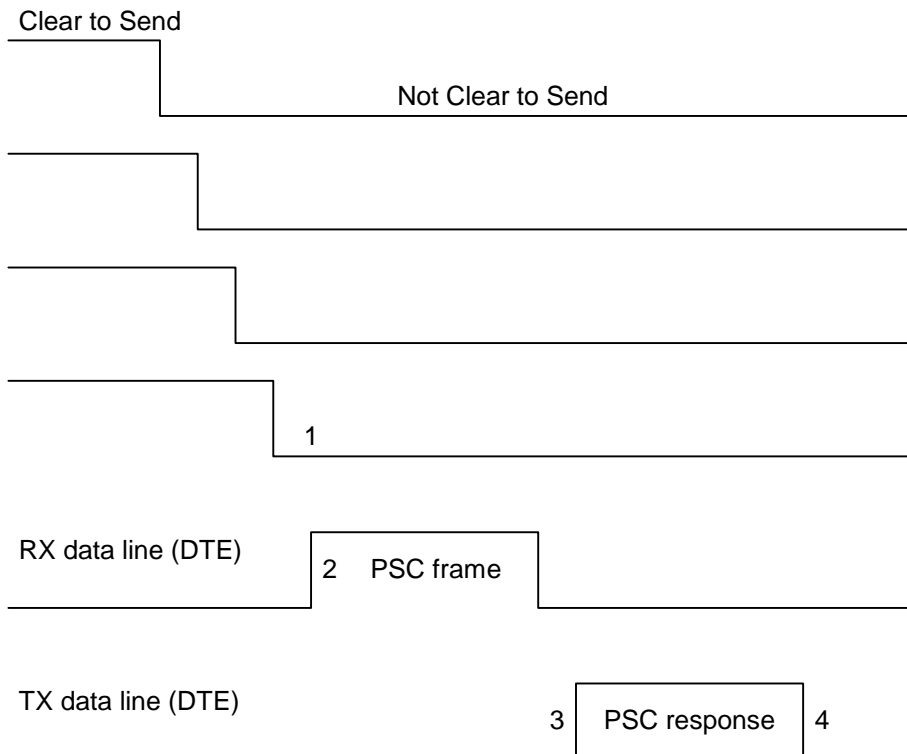

Appendixes to AT Commands Interface Guide for 6.57 Release

- 1: All the logical CTS are set high (each connected application can see CTS low)
- 2: Last CTS drop causes WAVECOM Wireless CPU (DCE) CMUX driver to send a PSC frame and to wait for the PSC response.
- 3: Application replies with a PSC response
- 4: All WAVECOM Wireless CPU serial virtual ports are in sleep mode state.

3.2.6 Wake up procedure

There are two different ways of waking up the Wireless CPU:

3.2.6.1 Wake up by DTE (e.g desktop PC) wakes up Wireless CPU with a 27.010 Wake up frame

In order to wake up the Wireless CPU, the client application has to trigger one of its connected DTR high like the physical scheme.

When wanting to send the DTR MSC protocol frame, the DTE MUST first sends F9F9F9 wake up frames, waiting for Wireless CPU response, and then sends as a valid frame the DTR on MSC frame.

Otherwise, the Wireless CPU might sleep on again if all DTR are detected low !

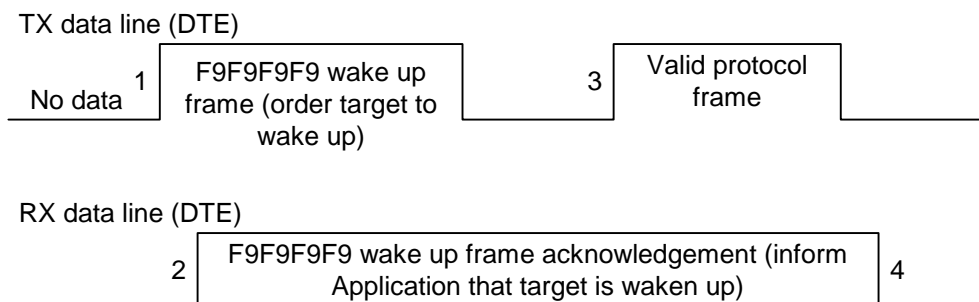

- 1: DTE sends 27.010 protocol F9F9F9F9 frame to wake up the asleep target.
- 2: DCE replies with 27.010 F9F9F9F9 wake up frame as acknowledgment and waits for a valid frame.
- 3: DTE sends a valid 27.010 frame in order to have the target stop its acknowledgment.
(It is required that the first valid frame is a MSC frame that raise application DTR)
- 4: DCE stops sending F9F9F9F9 answer after receiving this valid frame.

Appendixes to AT Commands Interface Guide for 6.57 Release

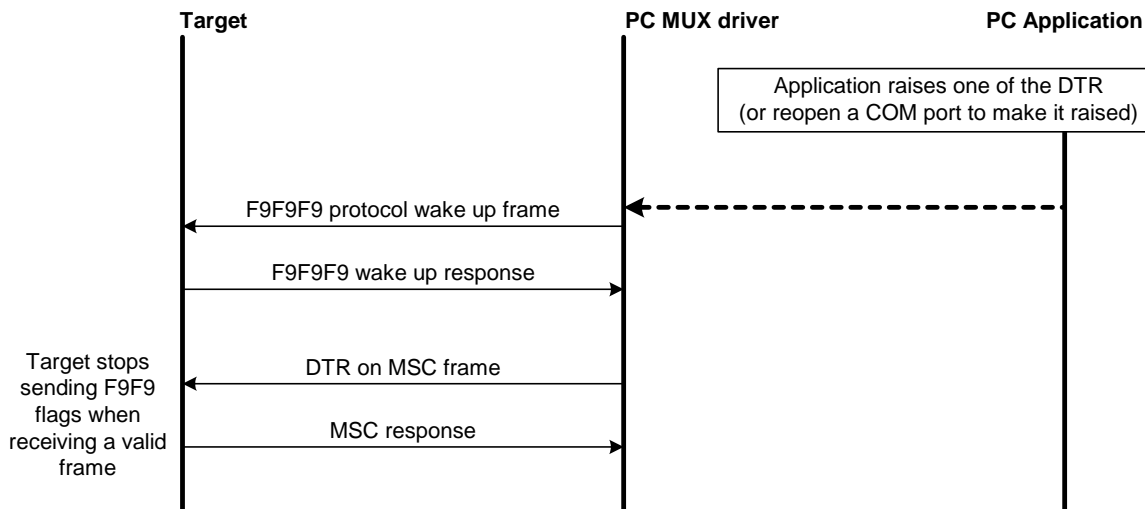

Note: If the valid frame is a DATA frame, the Wireless CPU does not detect any DTR change and sleeps on again with the PSC frame.

3.2.6.2 Wake up by WAVECOM Wireless CPU (DCE) (unsolicited AT response" e.g "RING" is to be sent)

Wireless CPU wakes up the DTE with a 27.010 protocol wake up frame first and then sends its unsolicited indication.

The protocol preliminary wake up sequence is described below:

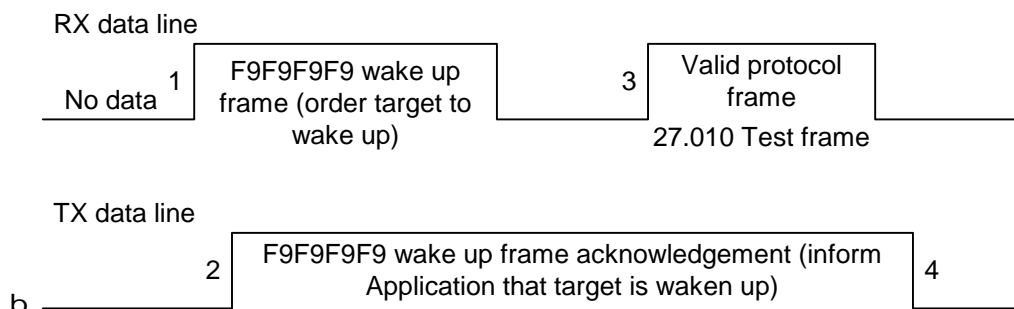

- 1: DCE sends 27.010 protocol F9F9F9F9 frame to wake up the asleep Application.
- 2: DTE replies with 27.010 F9F9F9F9 wake up frame as acknowledgment and waits for a valid frame.
- 3: DCE sends a valid 27.010 test frame in order to have the target stop its acknowledgment.
- 4: DTE stops sending F9F9F9F9 answer after receiving the valid frame.

Appendixes to AT Commands Interface Guide for 6.57 Release

The entire "unsolicited string" wake up sequence and sending is described below:

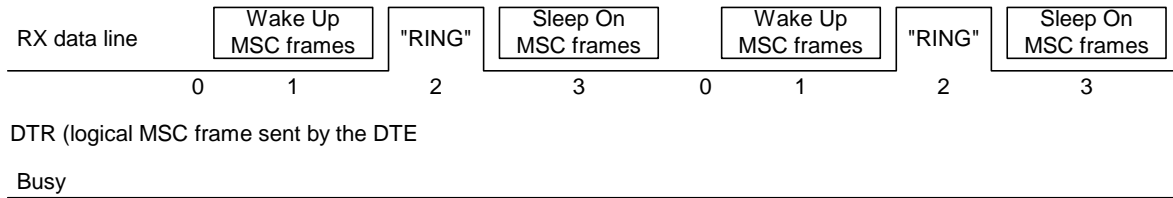

0: The DCE is disturbed with an incoming call.

1: DCE starts sending F9F9F9 wake up frame, waiting for its response and sending a valid test frame (0x4D ,0x55, 0x58, 0x57, 0x41, 0x4B, 0x45, 0x55, 0x50 = MUXWAKEUP). (Once waken up, the RI is sent before the RING string in our case)

2: The unsolicited response message is sent.

3: After the unsolicited response has been sent, the port is in sleep mode again (no more AT response and DTR low). Then DCE sends PSC to sleep on and waits for its response.

During the preliminary Wake Up sequence, if no F9F9F9 is received within T3 timer, the Wireless CPU takes the decision to close all the ports assuming that there is no more CMUX driver in the remote side.

Appendixes to AT Commands Interface Guide for 6.57 Release

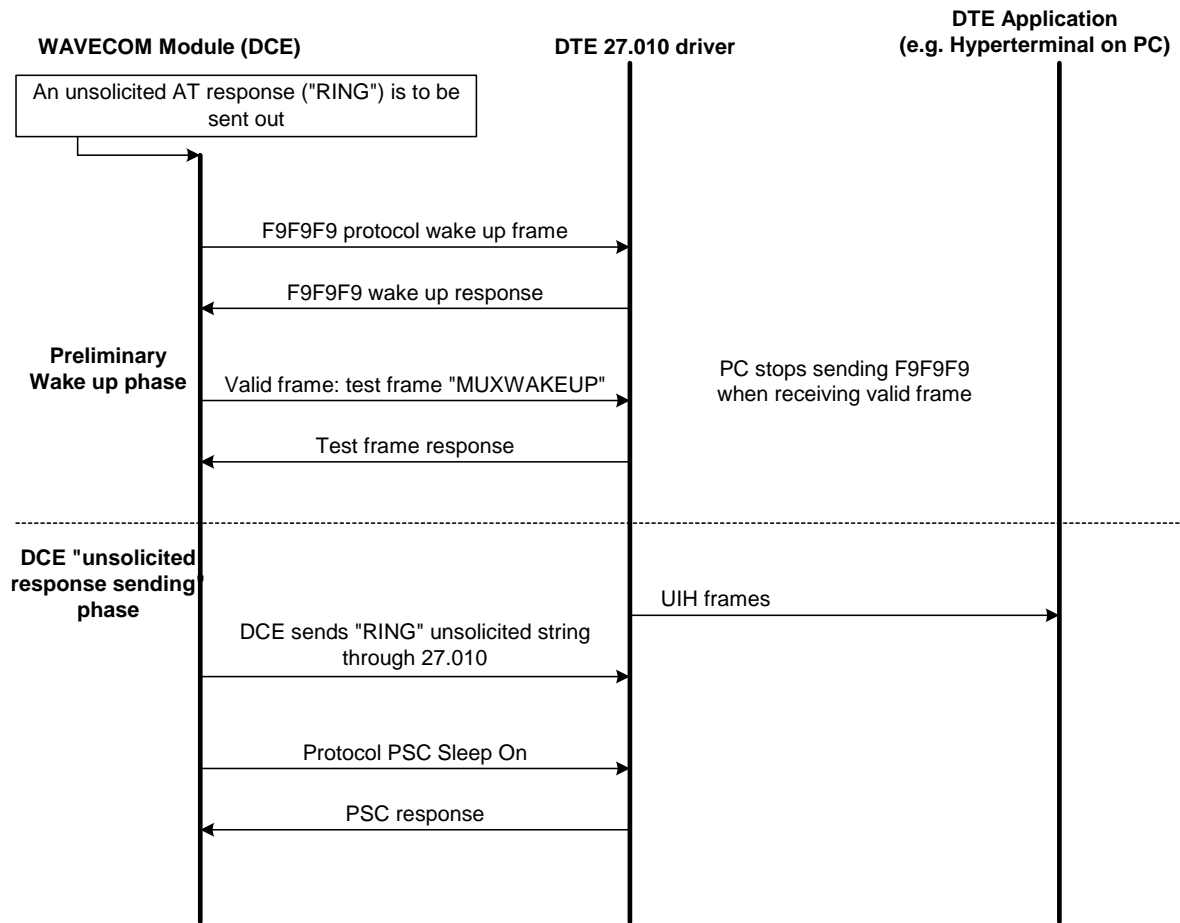

Appendixes to AT Commands Interface Guide for 6.57 Release

3.3 Support of SIM ToolKit by the M.E.

This has been extracted from the GSM Technical specification 11.14.

TABLE 1 – Support of SIM Toolkit classes

Command description	Classes		
	1	2	3
CALL CONTROL		X	X
CELL BROADCAST DOWNLOAD		X	X
DISPLAY TEXT		X	X
EVENT DOWNLOAD			
- MT call			X
- Call connected			X
- Call disconnected			X
- Location status			X
- User activity			X
- Idle screen available			X
GET INKEY		X	X
GET INPUT		X	X
GET READER STATUS \$(MultipleCard)\$			Lc
MENU SELECTION		X	X
MO SHORT MESSAGE CONTROL			X
MORE TIME		X	X
PERFORM CARD APDU \$(MultipleCard)\$			Lc
PLAY TONE		X	X
POLLING OFF		X	X
POLL INTERVAL		X	X
POWER ON CARD \$(MultipleCard)\$			Lc
POWER OFF CARD \$(MultipleCard)\$			Lc
PROVIDE LOCAL INFORMATION		X	X
REFRESH	X	X	X
RUN AT COMMAND \$(AT\$)			Lc
SELECT ITEM		X	X
SEND SHORT MESSAGE		X	X
SEND SS		X	X
SEND USSD			X
SET UP CALL		X	X
SET UP EVENT LIST			X
SET UP IDLE MODE TEXT \$(IdleModeText)\$			X
SET UP MENU		X	X
SMS-PP DOWNLOAD	X	X	X
TIMER MANAGEMENT \$(Timer)\$			Lc
TIMER EXPIRATION \$(Timer)\$			Lc

Appendixes to AT Commands Interface Guide for 6.57 Release

TABLE 2 - Compatibility between available Terminal Responses and Proactive Commands

Terminal Responses	Proactive commands											
	Setup Menu (0)	Display Text(1)	Get Inkey (2)	Get Input (3)	Setup Call (4)	Play Tone (5)	Select Item (6)	Refresh (7)	Send SS (8)	Send SMS (9)	Send USSD (10)	Setup event list (11)
Backward Move (95)		•	•	•			•					
Command beyond ME capabilities (96)	•	•	•	•	•	•	•	•	•	•	•	•
ME currently unable to process command (97)	•	•	•	•	•	•	•	•	•	•	•	•
No response from the user (98)		•	•	•			•					
SIM session terminated by the user (99)		•	•	•	•	•	•					

3.4 Structure of TERMINAL PROFILE

First byte (Download):

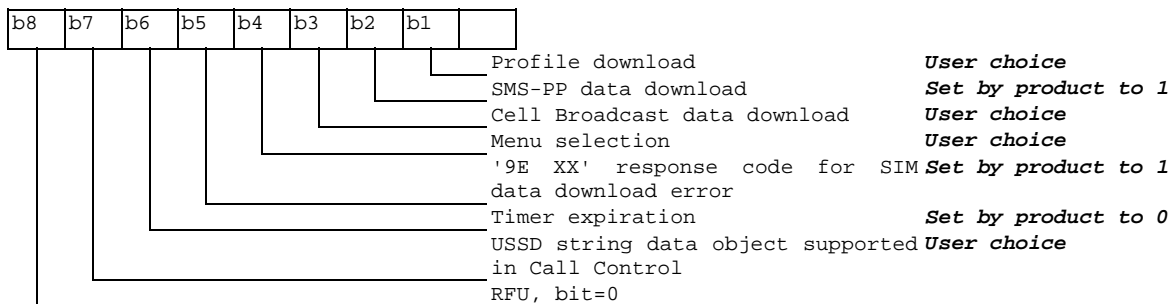

Appendixes to AT Commands Interface Guide for 6.57 Release

Second byte (Other):

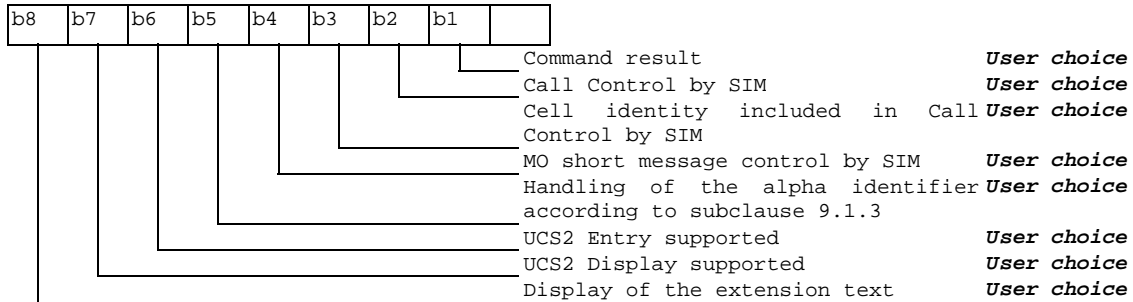

Third byte (Proactive SIM):

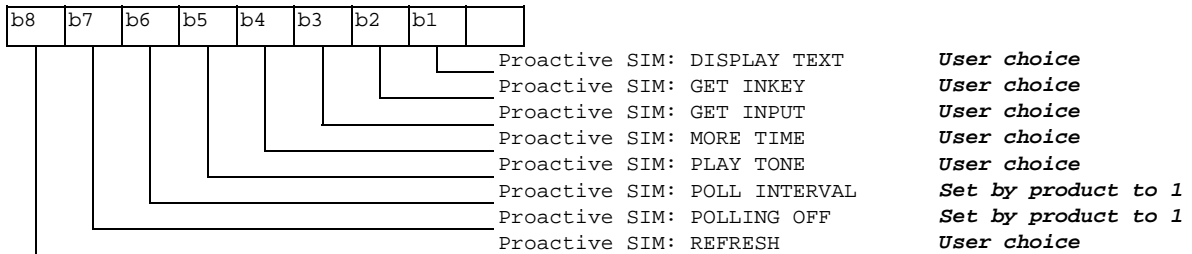

Fourth byte (Proactive SIM):

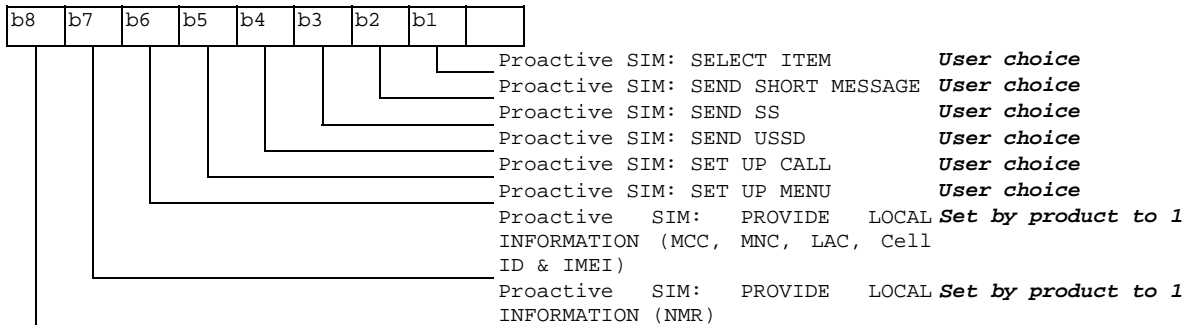

Fifth byte (Event driven information):

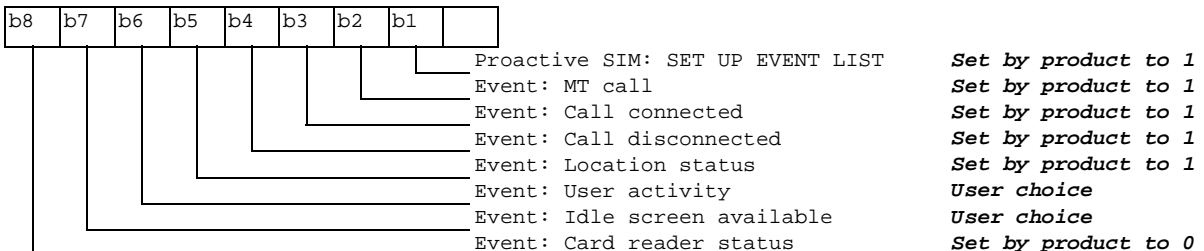

Appendixes to AT Commands Interface Guide for 6.57 Release

Sixth byte: (reserved for Event driven information extensions)

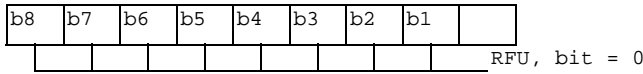

Seventh byte (Multiple card proactive commands) for class "a"

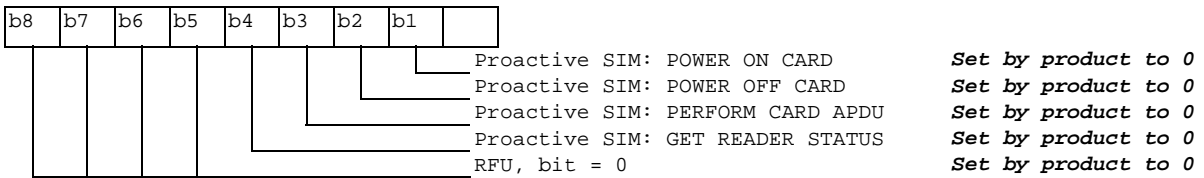

Eighth byte (Proactive SIM):

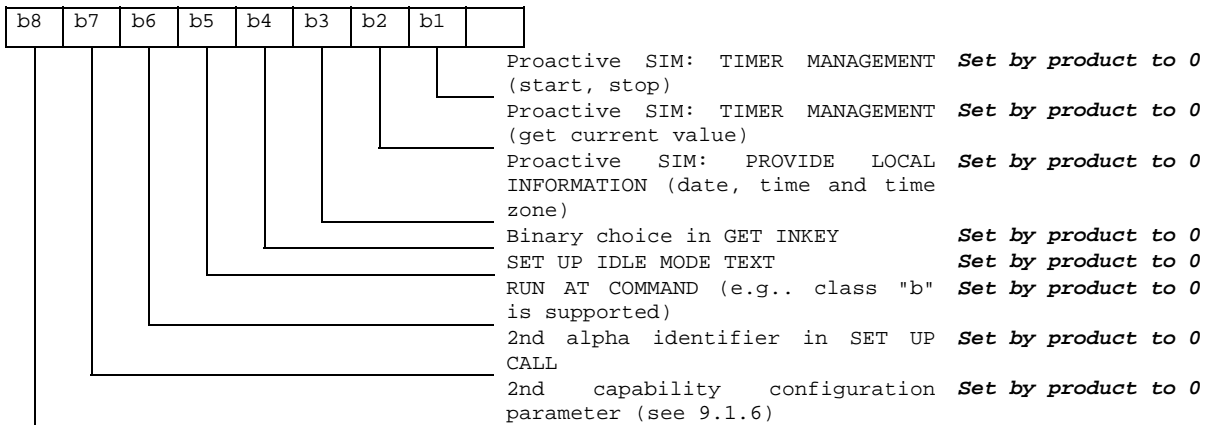

Ninth byte:

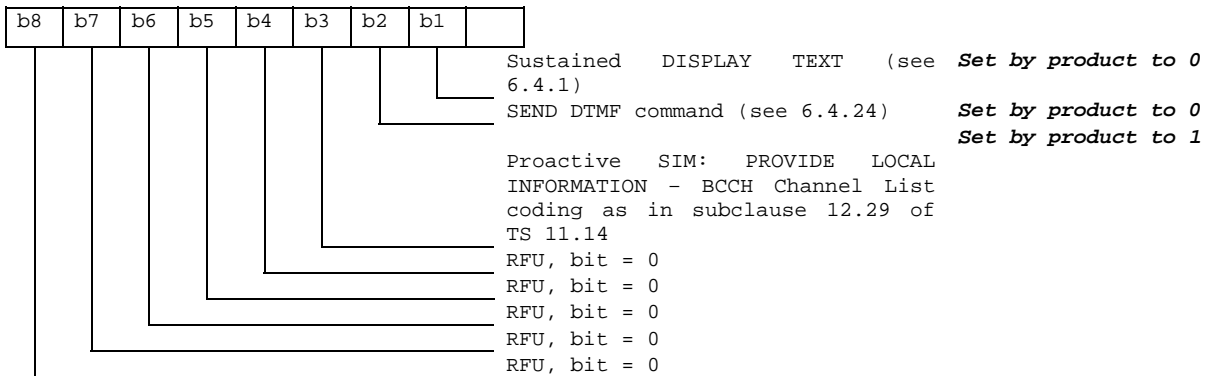

Subsequent bytes:

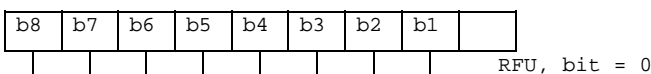

Appendixes to AT Commands Interface Guide for 6.57 Release

Information about BCCH channel list

(this is an extract of GSM Rec 11.14)

Byte(s)	Description	Length
1	BCCH channel list tag	1
2	Length (X) of bytes following	1
3 to X+2	BCCH channel list	X

- BCCH channel list

Contents: the list of absolute RF channels for BCCH carriers, as known by the ME from the SYSTEM INFORMATION messages. The BCCH channel list is composed of one to three BCCH channel sub lists, each sub list is derived from the set of frequencies defined by reference neighbor cells description information element or elements. In the latter case the set is the union of the different subsets defined by the neighbor cells description information elements (see TS 04.08 [8]). The length of the BCCH channel list field depends on the length of the received BCCH channel list derived from the different SYSTEM INFORMATION messages to be considered.

Coding: Each ARFCN (*Absolute Radio Frequency Channel Number*) is represented by 10 bits. Spare bit(s) are to be filled with 0.

	Bit 8	Bit 7	Bit 6	Bit 5	Bit 4	Bit 3	Bit 2	Bit 1
Byte 1	ARFCN#1 (high part)							
Byte 2	ARFCN#1 (low part)		ARFCN#2 (high part)					
Byte 3	ARFCN#2 (low part)				ARFCN#3 (high part)			
...	...							
Byte X-1	ARFCN#m-1 (low part)				ARFCN#m (high part)			
Byte X	ARFCN#m (low part)						Spare bit (0)	Spare bit(0)

SIM applications should take into account that early implementations of SIM application toolkit may have coded this field differently, because of an inconsistency between the content and the coding of this element in previous versions of 11.14. The SIM is able to identify MEs that are using the coding described above by

Appendixes to AT Commands Interface Guide for 6.57 Release

evaluating the indication "BCCH Channel List coding" in the TERMINAL PROFILE command.

3.5 Command Type and Next Action Indicator.

This table has been extracted from the GSM Technical specification 11.14.

Value	Name	Used for Type of Command coding	used for Next Action Indicator coding
'00'		-	-
'01'	REFRESH	X	
'02'	MORE TIME	X	
'03'	POLL INTERVAL	X	
'04'	POLLING OFF	X	
'05'	SET UP EVENT LIST	X	
'10'	SET UP CALL	X	X
'11'	SEND SS	X	X
'12'	SEND USSD	X	X
'13'	SEND SHORT MESSAGE	X	X
'14'	SEND DTMF	X	
'20'	PLAY TONE	X	X
'21'	DISPLAY TEXT	X	X
'22'	GET INKEY	X	X
'23'	GET INPUT	X	X
'24'	SELECT ITEM	X	X
'25'	SET UP MENU	X	X
'26'	PROVIDE LOCAL INFORMATION	X	
'27'	TIMER MANAGEMENT	X	
'28'	SET UP IDLE MODEL TEXT	X	X
'30'	PERFORM CARD APDU	class "a" only	X
'31'	POWER ON CARD	class "a" only	X
'32'	POWER OFF CARD	class "a" only	X
'33'	GET READER STATUS	class "a" only	X
'34'	RUN AT COMMAND	class "b" only	
'81'	End of the proactive session	not applicable	X

Appendixes to AT Commands Interface Guide for 6.57 Release

3.6 Coding of Alpha fields in the SIM for UCS2

The coding can take one of the three following structures, or GSM default alphabet. If the ME supports UCS2 coding of alpha fields in the SIM, it will support all three coding schemes for character sets containing 128 characters or less. For character sets containing more than 128 characters, the ME will at least support the first coding scheme. Within a record, only one coding scheme, either GSM default alphabet, or one of the three described below, can be used.

- 1) If the **first byte in the alpha string is '0x80'**, then the other bytes are 16 bit UCS2 characters. The most significant byte (MSB) of the UCS2 character is coded in the lower numbered byte of the alpha field, and the less significant byte (LSB) of the UCS2 character is coded in the higher numbered alpha field byte. In other words, byte 2 of the alpha field contains the most significant byte (MSB) of the first UCS2 character, and byte 3 of the alpha field contains the less significant byte (LSB) of the first UCS2 character (as shown below). Unused bytes shall be set to 'FF': if the alpha field has an even length in bytes, the last (unusable) byte will be set to 'FF'.

Example 1

Byte 1	Byte 2	Byte 3	Byte 4	Byte 5	Byte 6	Byte 7	Byte 8	Byte 9
'80'	Ch1 _{MSB}	Ch1 _{LSB}	Ch2 _{MSB}	Ch2 _{LSB}	Ch3 _{MSB}	Ch3 _{LSB}	'FF'	'FF'

- 2) If the **first byte of the alpha string is '0x81'**, then the 2nd byte contains a value indicating the number of characters in the string. The 3rd byte contains an 8 bit number which defines bits 15 to 8 of a 16 bit base pointer, where bit 16, and bits 7 to 1 would be set to zero. These sixteen bits represent a base pointer to a "half-page" in the UCS2 code space, to be used with some or all of the remaining bytes in the string. The 4th and subsequent bytes in the string contain coding as follows:
 - if bit 8 of the byte is set to zero, the remaining bits of the byte contain a GSM Default Alphabet character
 - if bit 8 of the byte is set to one, the remaining bits are an offset value to add to the 16 bit base pointer defined by byte 3, and the resulting 16 bit value is a UCS2 code point, and defines a UCS2 character.

Example 2

Byte 1	Byte 2	Byte 3	Byte 4	Byte 5	Byte 6	Byte 7	Byte 8	Byte 9
'81'	'05'	'13'	'53'	'95'	'A6'	'28'	'FF'	'FF'

Appendixes to AT Commands Interface Guide for 6.57 Release

In the example above

- Byte 2 indicates there are 5 characters in the string
 - Byte 3 indicates bits 15 to 8 of the base pointer, and indicates a bit pattern of 0hhh shah h000 0000 as the 16 bit base pointer number. Bengali characters for example start at code position 0980 (0000 1001 1000 0000), which is indicated by the coding '13' in byte 3 (shown by the italicized underlined digits).
 - Byte 4 indicates GSM Default Alphabet character '53', e.g.. "S".
 - Byte 5 indicates a UCS2 character offset to the base pointer of '15', expressed in binary as follows 001 0101, which, when added to the base pointer value results in a sixteen bit value of 0000 1001 1001 0101, e.g.. '0995', which is the Bengali letter KA.
 - Byte 8 contains the value 'FF': as the string length is 5, this a valid character in the string, where the bit pattern 111 1111 is added to the base pointer, yielding to a sixteen bit value of 0000 1001 1111 1111 for the UCS2 character (that is '09FF').
 - Byte 9 contains the padding value 0xFF.
- 3) **If the first byte of the alpha string is set to '0x82'**, then the 2nd byte contains the length of the string (number of characters).
 The 3rd and 4th bytes contain a 16 bit number which defines the complete 16 bit base pointer to a "half-page" in the UCS2 code space, for use with some or all of the remaining bytes in the string.
 The 5th and subsequent bytes in the string contain coding as follows:
- if bit 8 of the byte is set to zero, the remaining seven bits of the byte contain a GSM Default Alphabet character,
 - if bit 8 of the byte is set to one, the remaining seven bits are an offset value added to the base pointer defined in bytes 3 and 4, and the resulting 16 bit value is a UCS2 code point, and defines a UCS2 character.

Example 3

Byte 1	Byte 2	Byte 3	Byte 4	Byte 5	Byte 6	Byte 7	Byte 8	Byte 9
'82'	'05'	'05'	'30'	'2D'	'82'	'D3'	'2D'	'31'

In the example above:

- Byte 2 indicates there are 5 characters in the string
- Bytes 3 and 4 contain a 16 bit base pointer number of '0530', pointing to the first character of the Armenian character set.
- Byte 5 contains a GSM Default Alphabet character of '2D', which is a dash "-".
- Byte 6 contains a value '82', which indicates it is an offset of '02' added to the base pointer, resulting in a UCS2 character code of '0532', which represents Armenian character Capital BEN.
- Byte 7 contains a value 'D3', an offset of '53', which when added to the base pointer results in a UCS2 code point of '0583', representing Armenian Character small PIWR.

Appendixes to AT Commands Interface Guide for 6.57 Release

3.7 Specifications of Power down Control mechanism through serial Ports (physical ⇔ RS232 ports or virtual ⇔ CMUX ports)

3.7.1 What is new on X55 and further software releases

V24 Sleep mode and WAVECOM 32K mode used to be a one and only functionality. Since v24 now supports several ports (physical or virtual), WAVECOM products are allowed to enter 32K low consumption mode only when all of these ports are individually ready to enter such a mode.

3.7.2 Definitions

3.7.2.1 Serial port sleep mode state

This mode reflects the particular V24 state of a port (physical or virtual) regarding the possibility to enter or not 32K low consumption mode.

- This **mode is entered** automatically when :
 - The port is in AT command mode. (no GSM/GPRS communication is in progress on it).
 - No AT response is to be sent to the DTE.
 - The connected DTE is no more ready to communicate on it (meaning DTE sets DTR low).

- This **mode is left** automatically when some unsolicited responses are to be sent to the DTE.

The connected DTE is ready to communicate on it (meaning DTE sets DTR high).

CTS is set when in this mode, the DCE does not allow the DTE to send data to the involved serial port (meaning low on that port).

3.7.2.2 Serial ports sleep mode global state

This mode reflects the state of all the internal serial ports regarding their ability to enter 32K low consumption mode.

It is a Boolean (asleep or not) that authorizes or not GSM/GPRS protocol and Hardware Layers to enter 32K low consumption mode.

This mode is entered and left automatically depending on the state of all currently available serial ports (virtual or physical).

- Global V24 sleep **mode is entered** when all v24 available ports are in sleep mode state.

Appendixes to AT Commands Interface Guide for 6.57 Release

- Global V24 sleep **mode is left** when **at least one** of the v24 available ports is not in sleep mode state.

3.7.2.3 WAVECOM 32K low consumption mode

This mode is based on a slower clock (32KHz) that is used instead of 13MHz clock. Most of hardware blocks are stopped. It is aimed at reducing the power consumption.

This mode is entered and left automatically if the feature is allowed.

To activate this mode, the "+W32K" AT command must be used.

It is authorised or not by peripherals (such as UARTs, Buses, ...) and mainly driven by GSM/GPRS protocols and Hardware Layers : this mode is entered when no GSM/GPRS activity is required (no communication is in progress, no paging is in progress, ...).

Regarding UARTs and serial ports activity, 32K low consumption mode may be entered as soon as V24 sleep mode global state is "asleep".

WAVECOM Wireless CPU decides on its own to leave 32K low consumption at each GSM/GPRS paging occasion.

During, this little time (which is operator dependant), UARTs are activated again so that DTR state changes can be processed.

When this mode is activated, no data can be exchanged on RXD and TXD lines. Only Modem status changes can be monitored (DTR and RTS changes) by the DCE.

3.7.3 Summary

To summarize the 3 definitions, the following schematics describe the functional links between, **serial port sleep mode single state** manager, **serial ports sleep mode global state** manager and **W32K sleep mode** manager.

Appendixes to AT Commands Interface Guide for 6.57 Release

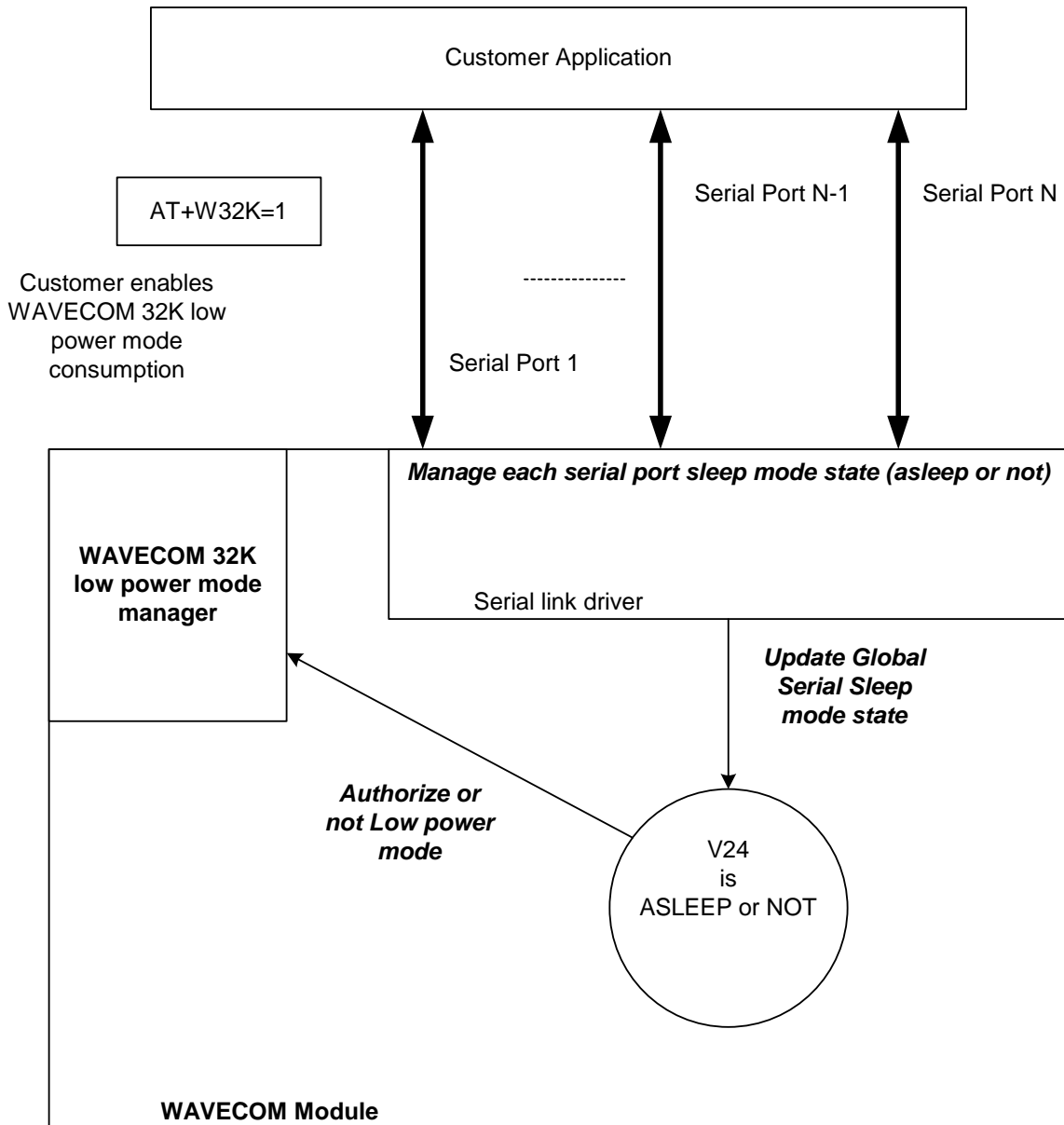

3.7.4 Case of single serial port use

This section describes the expected behaviour for a single serial port (physical or virtual). Please remember that this behaviour is independent of W32K feature activation.

Appendixes to AT Commands Interface Guide for 6.57 Release

3.7.4.1 Sleep on procedure

In order to place a serial port in Sleep Mode state, the DTE just has to drop its DTR signal to indicate that it is Busy. Then, WAVECOM Wireless CPU (DCE) sets the DTE CTS low.

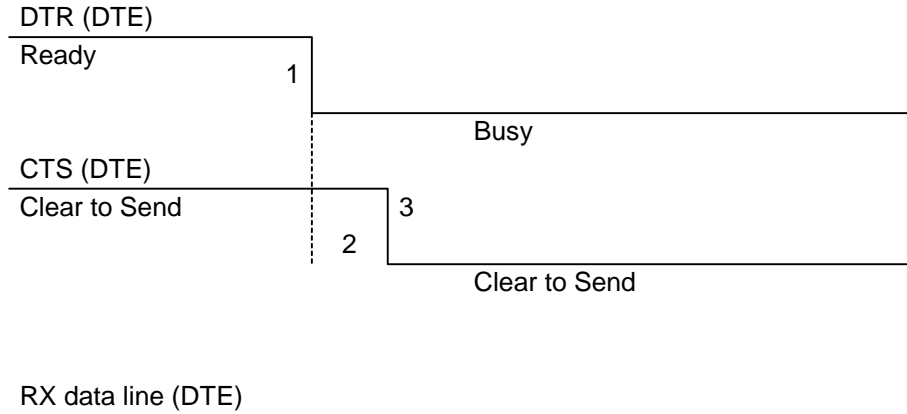

- 1: The application drops its DTR to indicate a busy state
- 2: WAVECOM Wireless CPU (DCE) detects DTR drop and check if there are still AT responses to send on that port.
- 3: When DTR is low and there are no more AT response, the DCE sets the application (DTE) CTS low. (At this point, the associated serial port is in Sleep Mode state)

Note: While in data mode, the CTS does not follow the DTR.

3.7.4.2 Wake Up procedures

3.7.4.2.1 On DTE initiative: Wake up by DTR Raise

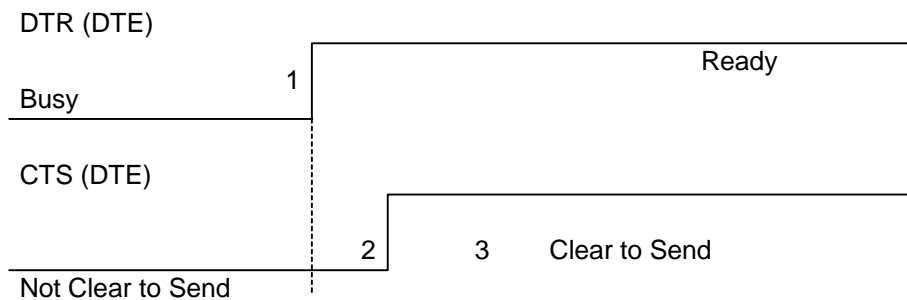

- 1: The application raises its DTR signal to indicate a ready state (meaning DTE wants to communicate with the DCE).
- 2: WAVECOM Wireless CPU (DCE) takes into account the DTR signal change. (MSR IRQ for physical port or protocol frame for CMUX)

Appendixes to AT Commands Interface Guide for 6.57 Release

3: V24 triggers the DTE CTS signal to allow AT commands again. (CTS is high)

3.7.4.2.2 On DCE initiative: Wake up by AT unsolicited indications (e.g. "RING " indicator)

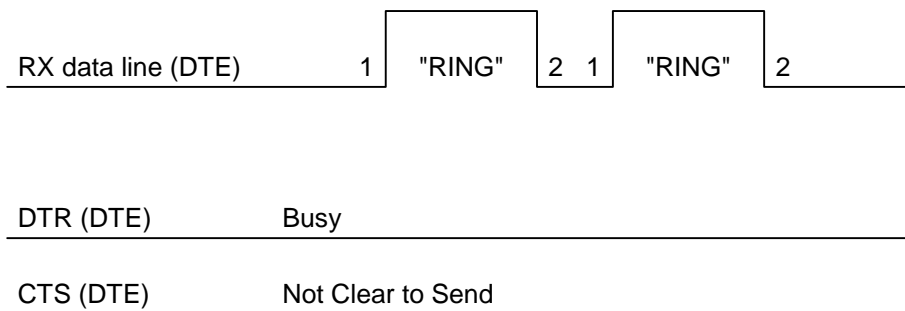

1: An incoming call occurs. Consequently unsolicited indications ("RING") are sent to the DTE.

2: As soon as unsolicited indication has been sent, the port switches back to sleep mode state (as long as there is no more AT command response to send and that DTR remains High)

3.7.4.3 Complete sequence behaviour

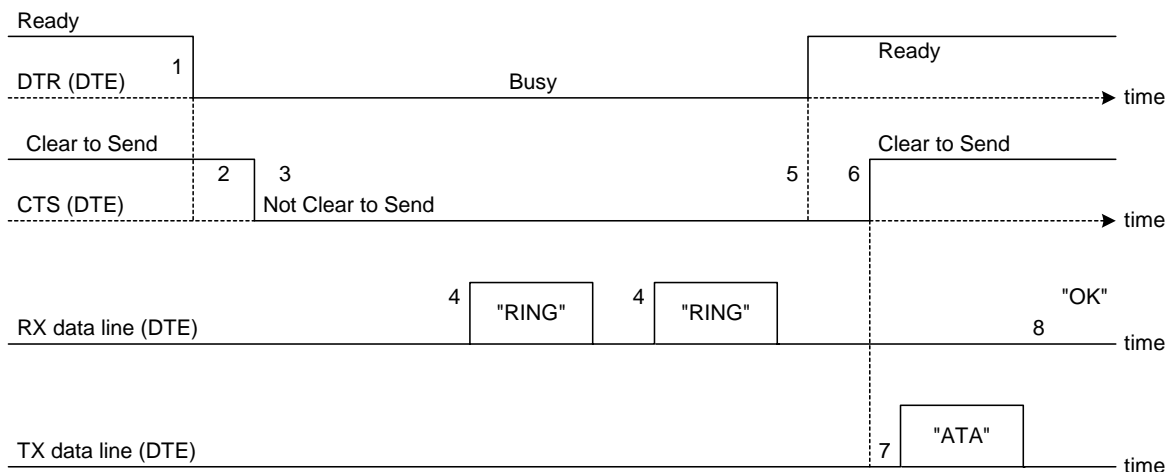

1: The application (DTE) drops its DTR to indicate to DCE a busy state

2: WAVECOM Wireless CPU (DCE) computes and check if there are still AT responses to send on that port.

Appendixes to AT Commands Interface Guide for 6.57 Release

3: Since no more AT response is to be sent, the DCE sets CTS to low so that application (DTE) can not send any data to the WAVECOM Wireless CPU (DCE). ⇔ **At this stage, the associated serial port is in Sleep Mode state.**

4: An incoming call occurs. As a consequence, unsolicited AT indications (e.g. "RING") are sent to the DTE.

Note that even if RING are sent, Serial Port remains in Sleep Mode state.

5: Customer application (DTE) wants to answer to "RING" unsolicited AT indications. It **MUST** raise first DTR to wake up the serial Port.

6: On WAVECOM Wireless CPU (DCE), detection of DTR rise informs that customer application (DTE) wants to get out from sleep mode state. DCE sets CTS high so that customer application (DTE) can send again data to WAVECOM Wireless CPU.

Note that at this stage, Serial Port is no more in Sleep Mode state.

7: Customer application (DTE) replies to RING indication with "ATA" command.

8: WAVECOM Wireless CPU (DCE) acknowledges and processes the command.

Note that this behaviour applies whether W32K is activated or not.

3.7.4.4 Transition state (from Asleep to Awake)

When unsolicited AT responses are to be sent (e.g. "RING" indication), V24 software elements enters a transition state that places the global sleep mode state in the "Awake State". Thus, until unsolicited responses are sent, the WAVECOM Wireless CPU can not enter Low power mode consumption (W32K). As a consequence, RTS signal **MUST** remain High to allow the transmission of the unsolicited response.

Note: mind that unsolicited responses are broadcasted on all available serial ports ⇔ **when unsolicited responses are to be sent (e.g. "RING") on a serial port and signals are not managed (e.g. RS232 cable is disconnected whereas associated V24 serial port is still registered) then WAVECOM Wireless CPU is not allowed to enter W32K low power mode consumption.**

3.7.5 Case of several serial ports use

The behaviour specified in §3.7.4 applies to each of the activated serial ports (physical or virtual e.g. CMUX).

Note: when WAVECOM 32K low power mode is activated (AT+W32K=1), **Wireless CPU really enters low power mode when all activated serial ports are set to sleep mode state.**

3.7.6 UART2 exception on ONEC1.3 based Wireless CPU (Q24xx, Q25xx, ...)

Physical block of the UART2 only provides Q24xx and Q25xx Wireless CPUs with RX/TX and CTS/RTS signals so that DTR can not be wired on UART2 serial port.

Appendixes to AT Commands Interface Guide for 6.57 Release

Since only RXD/TXD and RTS/CTS are available, there is no way to enter/leave sleep mode on this particular port.

Thus, UART2 is not scanned to manage global Serial Sleep mode state. As a consequence, **data can be lost on UART2 if W32k is activated.**

⇒ **WARNING** : when only UART2 is activated, activation of W32K mode is forbidden.

NOTE: when emulating one (or more) virtual port(s) over UART2 using CMUX feature, it is then possible to use W32K mode.

3.8 Description of Multi-Flow behavior

Multi-flows allows the Wireless CPU to treat commands from various sources (or flows):

- UART ports
- USB port
- embedded Open-AT applications.
- CMUX virtual ports

AT commands are organized in classes , and multi-flow allows the simultaneous execution of commands of different classes coming from the possible sources:

- commands belonging to the same class can not be treated as the same time. When a command of a class is treated, the Wireless CPU will respond "busy" to any command of the same class until the first command processing has completed.
- when a flow is waiting for the treatment of a command, it is busy until the command execution completion.

Example:

- 1) The Wireless CPU receives a command of class AT_CLASS_PHONEBOOK on UART1. The processing of the command starts, and a response from the phonebook entity is expected. No other command of the AT_CLASS_PHONEBOOK class can be processed, and the UART1 port is busy.
- 2) The Wireless CPU receives then a command from USB port, of another class. It is able to immediately process this second command.
- 3) When the phonebook entity answers, the first command's processing completes. UART1 port and AT_CLASS_PHONEBOOK class are released.

Notes:

- concatenation of commands remains possible,
- the Repeat command (A) runs independently for each flow,
- an embedded Open-AT application or "+WMFM" AT command may change data redirection.

Appendixes to AT Commands Interface Guide for 6.57 Release

3.8.1 Commands classes

There are 27 commands classes, presented in the array below:

Class name	Related commands
AT_CLASS_A_SLASH	A/
AT_CLASS_COM	+CHLD, +VTD, +VTS, +WATH, A, D, DL, H, O
AT_CLASS_CPHS	+CPHS, +WALS, +WMBN
AT_CLASS_DATA	+CRLP, +DOPT
AT_CLASS_FAX	+FBOR, +FBUF, +FCQ, +FCR, +FDCC, +FDIS, +FPHCT, +FRH, +FRM, +FRS, +FTH, +FTM, +FTS, FLID
AT_CLASS_GPRS	+CGACT, +CGANS, +CGATT, +CGAUT, +CGCLA, +CGDATA, +CGDCONT, +CGERE, +CGPAD, +CGQMI, +CGQRE, +CGREG, +CGSMS, +GCAP, +WGPRS
AT_CLASS_LOCATION	+WLOC
AT_CLASS_MAIN	%D, &C, &D, &E, &F, &S, &T, &V, &W, +ADC, +CALA, +CBST, +CCLK, +CEER, +CGMI, +CGMM, +CGMR, +CGSN, +CICB, +CIND, +CLCC, +CMEC, +CMEE, +CMER, +CMUT, +CMUX+CPAS, +CR, +CRC, +CREG, +CRMP, +CRSL, +CSCS, +CSNS, +CSVM, +ECHO, +FCLASS, +ICF, +IFC, +ILRR, +IPR, +SIDET, +SPEAK, +VGR, +VGT, +VIP, +W32K, +WAC, +WBCM, +WBM, +WBR, +WBW, +WCCS, +WCDM, +WCDP, +WCFM, +WCTM, +WDOP, +WDR, +WDTMF, +WDWL, +WFM, +WHWV, +WIMEI, +WIND, +WIOM, +WIOR, +WLOW, +WLCK, +WMIR, +WMSN, +WMUX, +WOPEN, +WPCS, +WRIM, +WRST, +WSCAN, +WSST, +WSSW, +WSTR, +WSVG, +WSVN, +WTONE, +WVR, E, I, Q, S, V, Z, +WMFM, +WOPEN, +WCOS
AT_CLASS_NETWORK	+CCED, +COPN, +COPS, +CPLS, +CPOL, +CSQ, +WMBS, +WOPN, +WOLM
AT_CLASS_PHONEBOOK	+CNUM, +CPBF, +CPBN, +CPBP, +CPBR, +CPBS, +CPBW, +WAIP, +WDCP
AT_CLASS_PHONEBOOK	WPGW, WPGR, WPGS
AT_CLASS_POFF	+CFUN, +CPOF, +WBHV
AT_CLASS_RIL	+CRSM, +CSIM
AT_CLASS_RS	+CPWL
AT_CLASS_SECURITY	+CLCK, +CPIN, +CPIN2, +CPINC, +CPWD
AT_CLASS_SIM	+CCID, +CIMI, +WLPR, +WLPW

Appendixes to AT Commands Interface Guide for 6.57 Release

Class name	Related commands
AT_CLASS_SMS	+CMGD, +CMGF, +CMGL, +CMGR, +CMGS, +CMGW, +CMSS, +CNMA, +CNMI, +CPMS, +CRES, +CSAS, +CSCA, +CSCB, +CSDH, +CSMP, +CSMS, +WCBM, +WMGO, +WMSC, +WUSS, +WMCP
AT_CLASS_SS	+CACM, +CMM, +CAOC, +CCFC, +CCUG, +CCWA, +CKPD, +CLIP, +CLIR, +COLP, +CPUC, +CSSN, +CUSD
AT_CLASS_STLK	+STGI, +STGR, +STIN, +STSF
AT_CLASS_V24B	%C, \N, +DR, +DS

3.8.2 Remark on error 536

When a class is locked and when another command belonging to the same class arrives, Wireless CPU answers +CME ERROR: 536.

Appendixes to AT Commands Interface Guide for 6.57 Release

4 Command execution and dependence to SIM

These arrays list all the AT command. For each, a column indicates the command execution condition (if +WIND:4 must have occurred OK, for example). SIM dependency column indicates if the command behavior will vary if another card is used (for example, it will be the case for phonebook reading commands). The Intermediate column indicates if intermediate responses can occur for the considered command.

4.1 General commands

AT commands	Conditions	SIM dependence	Intermediate
AT+CGMI	+WIND: 3	N	N
AT+CGMM	+WIND: 3	N	N
AT+CGMR	+WIND: 3	N	N
AT+CGSN	+WIND: 3	N	N
AT+CSCS	+WIND: 4	N	N
AT+WPCS	+WIND: 4	N	N
AT+CIMI	+WIND: 4	Y	N
AT+CCID	+WIND: 1	Y	N
AT+GCAP	+WIND: 3	N	N
A/	Depends on previous command	Depends on previous command	N
AT+CPOF	+WIND: 3 without SIM, +WIND: 1 with SIM	N	N
AT+CFUN	+WIND: 3	N	N
AT+CPAS	+WIND: 3	N	N
AT+CMEE	+WIND: 3	N	N
AT+CKPD	Depends of the sequence used	Y/N	N
AT+CCLK	+WIND: 3	Y	N
AT+CALA	+WIND: 3	N	Y
AT+CRMP	+WIND: 3	N	N
AT+CRSL	+WIND: 3	N	N
AT+CMUX		N	N

Appendixes to AT Commands Interface Guide for 6.57 Release

4.2 Call Control commands

AT commands	Conditions	SIM dependence	Intermediate
ATD	Depends of sequence used	Y/N	Y
ATH	+WIND: 3	N	N
ATA	+WIND: 3	N	N
AT+CEER	+WIND: 4	Y	N
AT+VTD	+WIND: 3	N	N
AT+VTS	+WIND: 5	N	N
ATDL	+WIND: 3	N	Y
AT%D	+WIND: 3	N	N
ATSO	+WIND: 3	N	N
AT+CICB	+WIND: 3	N	N
AT+CSNS	+WIND: 3	N	N
AT+VGR	+WIND: 3	N	N
AT+VGT	+WIND: 3	N	N
AT+CMUT	+WIND: 5	N	N
AT+SPEAKER	+WIND: 3	N	N
AT+ECHO	+WIND: 3	N	N
AT+SIDET	+WIND: 3	N	N
AT+VIP	+WIND: 3	N	N

4.3 Network service commands

AT commands	Conditions	SIM dependence	Intermediate
AT+CSQ	+WIND: 3	N	N
AT+COPS	+WIND: 4	Y	N
AT+CREG	+WIND: 3	N	Y
AT+WOPN	+WIND: 3	N	N
AT+CPLS	PIN	Y	N
AT+CPOL	After PIN entered	Y	Y
AT+COPN	After PIN entered	N	N

Appendixes to AT Commands Interface Guide for 6.57 Release

4.4 Security commands

AT commands	Conditions	SIM dependence	Intermediate
AT+CPIN	+WIND: 1	Y	N
AT+CPIN2	after PIN entered	Y	N
AT+CPINC	+WIND: 1	Y	N
AT+CLCK	+WIND: 4	Y	N
AT+CPWD	+WIND: 4	Y	N

4.5 Phonebook commands

AT commands	Conditions	SIM dependence	Intermediate
AT+CPBS	+WIND: 4	Y	N
AT+CPBR	+WIND: 4	Y	Y
AT+CPBF	+WIND: 4	Y	Y
AT+CPBW	+WIND: 4	Y	N
AT+CPBP	+WIND: 4	Y	Y
AT+CPBN	+WIND: 4	Y	Y
AT+CNUM	+WIND: 4	Y	N
AT+WAIP	+WIND: 3	N	N
AT+WDCP	+WIND: 4	Y	N
AT+CSVM	+WIND: 4	N	N
AT+WCOS	+WIND: 3	N	N
AT+WPGW	+WIND: 4	N	N
AT+WPGR	+WIND: 4	N	Y
AT+WPGS	+WIND: 4	N	Y

4.6 Short Messages commands

AT commands	Conditions	SIM dependence	Intermediate
AT+CSMS	+WIND: 16	Y	N
AT+CNMA	+WIND: 16	Y	N
AT+CPMS	+WIND: 16	Y	N
AT+CMGF	+WIND: 3	N	N
AT+CSAS	+WIND: 3	Y	N
AT+CRES	+WIND: 3	Y	N
AT+CSDH	+WIND: 16	Y	N
AT+CNMI	+WIND: 16	Y	N
AT+CMGR	+WIND: 16	Y	Y
AT+CMGL	+WIND: 16	Y	Y
AT+CMGS	+WIND: 16	Y	N
AT+CMGW	+WIND: 16	Y	Y
AT+CMSS	+WIND: 16	Y	N

Appendixes to AT Commands Interface Guide for 6.57 Release

AT commands	Conditions	SIM dependence	Intermediate
AT+CSMP	+WIND: 16	Y	N
AT+CMGD	+WIND: 16	Y	N
AT+CSCA	+WIND: 16	Y	N
AT+CSCB	+WIND: 16	Y	N
AT+WCBM	+WIND: 16	Y	N
AT+WMSC	+WIND: 16	Y	Y
AT+WMGO	+WIND: 16	Y	N
AT+WUSS	+WIND: 3	N	N
AT+WMCP	+WIND: 16	Y	N
AT+CMMS	+WIND: 3	Y	N

4.7 Supplementary Services commands

AT commands	Conditions	SIM dependence	Intermediate
AT+CCFC	+WIND: 4	Y	N
AT+CLCK	+WIND: 4	Y	N
AT+CPWD	+WIND: 4	Y	N
AT+CCWA	+WIND: 4	Y	N
AT+CLIR	After PIN entered	Y	N
AT+CLIP	After PIN entered	Y	N
AT+COLP	After PIN entered	Y	N
AT+CAOC	After PIN entered	Y	Y
AT+CACM	After PIN entered	Y	N
AT+CAMM	After PIN entered	Y	N
AT+CPUC	After PIN entered	Y	N
AT+CHLD	+WIND: 5,2	Y	N
AT+CLCC	+WIND: 3	N	N
AT+CSSN	+WIND: 3	N	N
AT+CUSD	+WIND: 3	N	N
AT+CCUG	+WIND: 4	Y	Y

Appendixes to AT Commands Interface Guide for 6.57 Release

4.8 Data commands

AT commands	Conditions	SIM dependence	Intermediate
AT+CBST	+WIND: 3	N	N
AT+FCLASS	+WIND: 3	N	N
AT+CR	+WIND: 3	N	N
AT+CRC	+WIND: 3	N	N
AT+ILRR	After PIN entered	N	N
AT+CRLP	+WIND: 3	N	N
AT+DOPT	+WIND: 3	N	N
AT%C	+WIND: 3	N	N
AT+DS	+WIND: 3	N	N
AT+DR	+WIND: 3	N	N
\N	+WIND: 3	N	N

4.9 Fax commands

AT commands	Conditions	SIM dependence	Intermediate
AT+FTM	+WIND: 3	N	N
AT+FRM	+WIND: 3	N	N
AT+FTH	+WIND: 3	N	N
AT+FRH	+WIND: 3	N	N
AT+FTS	+WIND: 3	N	N
AT+FRS	+WIND: 3	N	N

4.10 Class 2 Commands

AT commands	Conditions	SIM dependence	Intermediate
AT+FDT	+CLCC:X,X,0,2,X (fax call)	N	N
AT+FDR	+CLCC:X,X,0,2,X (fax call)	N	N
AT+FET	+CLCC:X,X,0,2,X (fax call)	N	N
AT+FPTS	+CLCC:X,X,0,2,X (fax call)	N	N
AT+FK	+CLCC:X,X,0,2,X (fax call)	N	N
AT+FBOR	+WIND: 3	N	N
AT+FBUF	+WIND: 3	N	N
AT+FCQ	+WIND: 3	N	N
AT+FCR	+WIND: 3	N	N
AT+FDIS	+WIND: 3	N	N
AT+FDCC	+WIND: 3	N	N
AT+FLID	+WIND: 3	N	N
AT+FPHCTO	+WIND: 3	N	N

Appendixes to AT Commands Interface Guide for 6.57 Release

4.11 V24-V25 commands

AT commands	Conditions	SIM dependence	Intermediate
AT+IPR	+WIND: 3	N	N
AT+ICF	+WIND: 3	N	N
AT+IFC	+WIND: 3	N	N
AT&C	+WIND: 3	N	N
AT&D	+WIND: 3	N	N
AT&S	+WIND: 3	N	N
ATO	+CLCC:X,0,0,1,X (data call)	N	N
ATQ	+WIND: 3	N	N
ATV	+WIND: 3	N	N
ATZ	+WIND: 3	N	N
AT&W	+WIND: 3	N	N
AT&T	+WIND: 3	N	N
ATE	+WIND: 3	N	N
AT&F	+WIND: 3	N	N
AT&V	+WIND: 3	N	N
ATI	+WIND: 3	N	N
AT+WMUX	+WIND: 3	N	N

4.12 Specific AT commands

AT commands	Conditions	SIM dependence	Intermediate
AT+CCED	+WIND: 3	N	N
AT+WIND	+WIND: 3	N	N
AT+ADC	+WIND: 3	N	N
AT+CMER	+WIND: 3	N	N
AT+CIND	+WIND: 3	N	N
AT+CMEC	+WIND: 3	N	N
AT+WLPR	+WIND: 1	N	N
AT+WLPW	+WIND: 1	N	N
AT+WIOR	+WIND: 3	N	N
AT+WIOW	+WIND: 3	N	N
AT+WIOM	+WIND: 3	N	N
AT+WAC	+WIND: 3	N	N
AT+WTONE	+WIND: 3	N	N
AT+WDTMF	+WIND: 3	N	N
AT+WDWL	+WIND: 3	N	N
AT+WVR	+WIND: 3	N	N
AT+WDR	+WIND: 3	N	N
AT+WHWV	+WIND: 3	N	N

Appendixes to AT Commands Interface Guide for 6.57 Release

AT commands	Conditions	SIM dependence	Intermediate
AT+WDOP	+WIND: 3	N	N
AT+WSVG	+WIND: 3	N	N
AT+WSTR	+WIND: 3	N	N
AT+WSCAN	+WIND: 3	N	N
AT+WRIM	+WIND: 3	N	N
AT+W32K	+WIND: 3	N	N
AT+WCDM	+WIND: 3	N	N
AT+WSSW	+WIND: 3	N	N
AT+WCCS	+WIND: 4	N	N
AT+WLCK	None (PIN for auto CNL)	N (Y for auto CNL)	N
AT+CPHS	+WIND: 4	Y	N
AT+WBCM	+WIND: 3	N	N
AT+WFM	+WIND: 3	N	N
AT+WCFM	+WIND: 3	N	N
AT+WMIR	+WIND: 3	N	N
AT+WCDP	+WIND: 3	N	N
AT+WMBN	PIN	Y	N
AT+WALS	+WIND: 4	Y	N
AT+WOPEN	+WIND: 3	N	N
AT+WRST	+WIND: 3	N	N
AT+WSST	+WIND: 3	N	N
AT+WLOC	PIN Code	Y	N
AT+WBR	+WIND: 3	N	N
AT+WBW	+WIND: 3	N	N
AT+WBM	+WIND: 3	N	N
AT+WATH	+WIND: 3	N	N
AT+WIMEI	+WIND: 3	N	N
AT+WSVN	+WIND: 3	N	N
AT+WMBS	+WIND: 3	N	N
AT+WMFM	+WIND: 3	No	No
AT+WBHV	+WIND: 3	N	N

4.13 SIM Toolkit commands

AT commands	Conditions	SIM dependence	Intermediate
AT+STSF	+WIND: 3	N	N
AT+STIN	+WIND: 4	Y	N
AT+STGI	+WIND: 4	Y	N
AT+STGR	+WIND: 4	Y	N

Appendixes to AT Commands Interface Guide for 6.57 Release

4.14 GPRS commands

AT commands	Conditions	SIM dependence	Intermediate
AT+CGDCONT	+WIND: 4		
AT+CGQREQ	+WIND: 4		
AT+CGQMIN	+WIND: 4		
AT+CGATT	+WIND: 4		
AT+CGACT	+WIND: 4		
AT+CGDATA	+WIND: 4		
AT+CGCLASS	+WIND: 3	N	N
AT+CGCLASS	+WIND: 4		
AT+CGSMS	+WIND: 4		
AT+CGREP	+WIND: 4		
AT+CGREG	+WIND: 4		
AT+CGAUTO	+WIND: 4		
AT+CGANS	+WIND: 4		
AT+CGADDR	+WIND: 4		
AT+WGPRS	+WIND: 3	None	N

Appendixes to AT Commands Interface Guide for 6.57 Release

5 Interoperability

All the commands listed below are only used for interoperability with other applications. They have no action and always reply OK.

Command	Responses
ATB	OK
ATC	OK
ATG	OK
ATL	OK
ATM	OK
ATN	OK
ATP	OK
ATT	OK
ATW	OK
ATX	OK
ATY	OK
ATK	OK
AT&E	OK
AT&G	OK
AT&K	OK
AT&P	OK
AT&Q	OK
AT&R	OK
AT&Y	OK
AT+GOI	OK
AT+GCI	OK

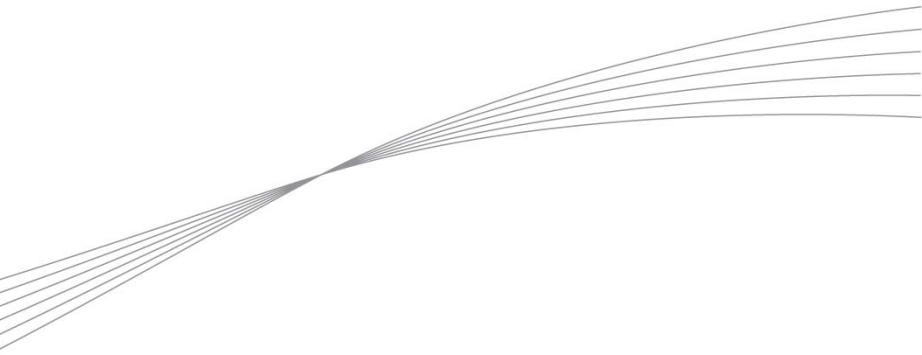

wavecom 

Make it wireless

WAVECOM S.A. - 3 esplanade du Foncet - 92442 Issy-les-Moulineaux Cedex - France - Tel: +33(0)1 46 29 08 00 - Fax: +33(0)1 46 29 08 08
Wavecom, Inc. - 4810 Eastgate Mall - Second Floor - San Diego, CA 92121 - USA - Tel: +1 858 362 0101 - Fax: +1 858 558 5485
WAVECOM Asia Pacific Ltd. - Unit 201-207, 2nd Floor, Bio-Informatics Centre - No.2 Science Park West Avenue - Hong Kong Science Park, Shatin
- New Territories, Hong Kong

www.wavecom.com