

# DM1800-434MR

## 433.92 MHz Transceiver Module

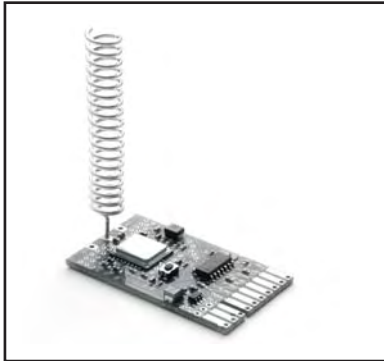

• *Network Router*

- *Compatible with RFM miniMESH™ Network Protocol*
- *3 V, Very Low Current Operation*
- *Ready-to-Use OEM Module*

The DM1800-434MR is the 433.92 MHz router module in the DM1800 family of RF transceivers. The DM1800 family is designed for adding wireless mesh connectivity to a wide range of monitoring and control systems. This module is compatible with RFM miniMESH™ network protocol, which provides add-on “plug- and-play” multicast mesh network routing. Radio communications range in an “open field” environment is typically 200 meters/hop. The DM1800-434MR combines RFM’s very low current ASH radio technology with low power microcontroller technology to achieve long battery life. The DM1800-434MR is designed for operation under ETSI I-ETS 300 220 regulations.

**Absolute Maximum Ratings**

Rating	Value	Units
All Input/Output Pins Except VIN	-0.3 to +3.3	V
Non-Operating Ambient Temperature Range	-40 to +85	°C

**Electrical Characteristics**

Characteristic	Sym	Notes	Minimum	Typical	Maximum	Units
Operating Frequency	f <sub>o</sub>		433.72		434.12	MHz
Modulation Type				OOK		
RF Encoded Data Transmission Rate				4.8		kb/s
Average Receiver Input Current, No External Power Supply Load	I <sub>R</sub>			4		mA
Receiver Input Signal for 10 <sup>-3</sup> BER, 25 °C				-100		dBm
Peak Transmitter Input Current, No External Power Supply Load	I <sub>TP</sub>				13.5	mA
Peak Transmitter Output Power	P <sub>O</sub>			1		mW
Bind Input Logic High			2.4			V
Bind Input Logic Low					.45	V
Average Sleep Input Current, No External Power Supply Load	I <sub>SA</sub>			90		µA
Power Supply Input Voltage Range	VIN		2.6		10	V
Regulated Power Supply Output Voltage, VIN 3.1 to 10 V	VOU <sub>T</sub>			3.0		Vdc
Regulated Power Supply Voltage Ripple					10	mV <sub>P-P</sub>
Operating Temperature Range			-40		85	°C
Relative Humidity Range, Non-Condensing	RH		10		90	%

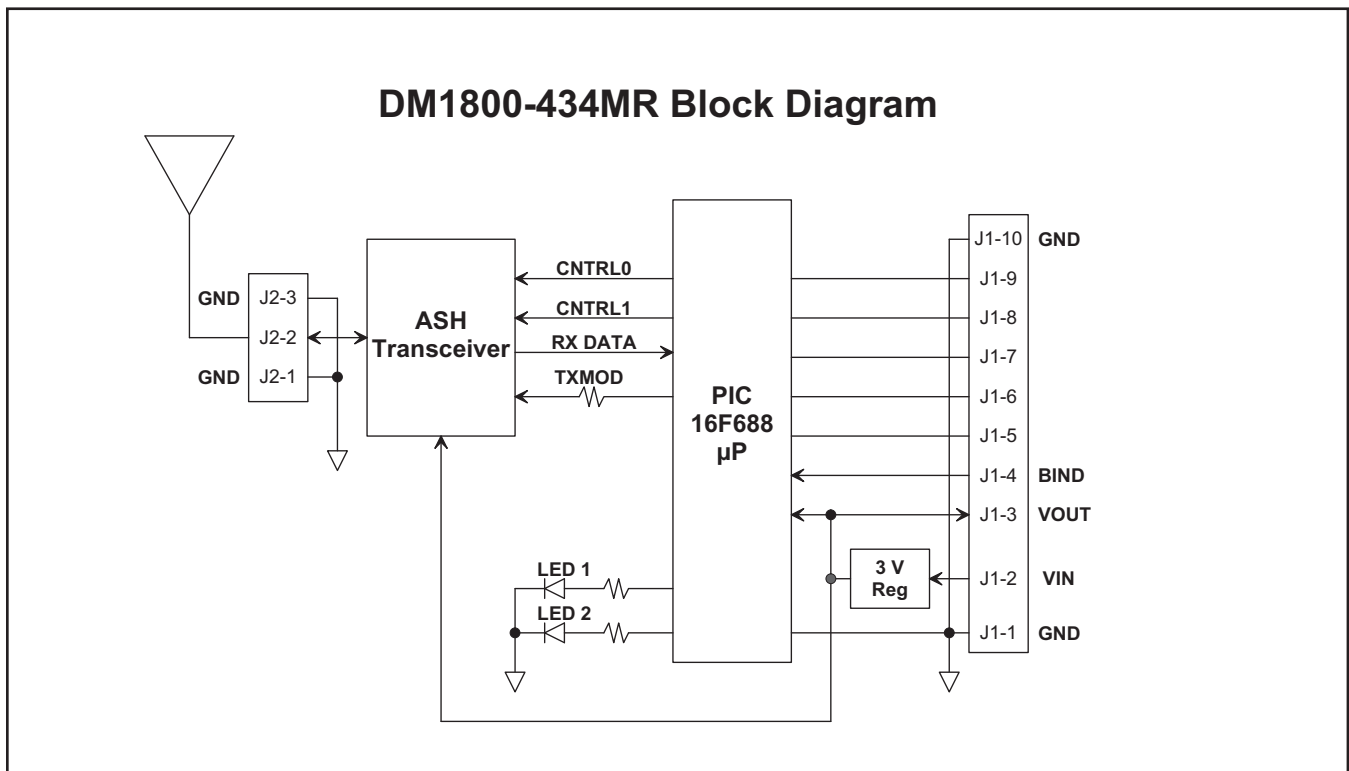

Figure 1

## Theory of Operation

The major components of the DM1800- 434MR include an RFM TR3000 ASH transceiver and a Microchip PIC16F688 micro- controller. The TR3000 operates on a frequency of 433.92 MHz, at a nominal output power of 1 mW. The DM1800-434MR includes two LEDs that indicate the module's operating mode.

The DM1800-434MR firmware is based on RFM miniMESH network protocol, which utilizes time-synchronized redundant routing

to provide robust, deterministic packet delivery through a network with up to 7 routers. Network configuration and maintenance features are built into the miniMESH protocol, simplifying commissioning and operating logistics. The firmware also includes several sleep cycling methods for extended battery life operation.

Please refer to the *DM1800 User's Guide* and the *AN1800 series Application Notes* for installation and application programming information. See the RFM web site at [www.RFM.com](http://www.RFM.com).

## DM1800-434MR I/O Pad Descriptions

Pin	Name	Description
J1-1	GND	This pad is a signal and power supply ground.
J1-2	VIN	This is the power supply input pad. The allowed input voltage range is 2.6 to 10 V.
J1-3	VOUT	VOUT tracks 50 to 100 mV below VIN when VIN is in the range of 2.6 to 3.1 V. When VIN is in the range of 3.1 to 10 V, VOUT is regulated at 3.0 Vdc. Up to 10 mA can be supplied from this pad for powering external circuits such as thermistor-resistor networks. External circuitry must not impress more than 10 mV <sub>p-p</sub> ripple on the regulated output voltage.
J1-4	BIND Input	This pad is connected to a logic input on the microcontroller, and is configured with a weak pull-up. When this pin is momentarily grounded (to J1-1 or J1-10, the module is placed into the bind mode, allowing this module to be associated with other modules to form a network.
J1-5	-	This pad is unused in router operation. Leave this pad electrically unconnected.
J1-6	-	This pad is unused in router operation. Leave this pad electrically unconnected.
J1-7	-	This pad is unused in router operation. Leave this pad electrically unconnected.
J1-8	-	This pad is unused in router operation. Leave this pad electrically unconnected.
J1-9	-	This pad is unused in router operation. Leave this pad electrically unconnected.
J1-10	GND	This pad is a signal and power supply ground.
J2-1	GND	This pad is a ground for the antenna port.
J2-2	ANT	This pad is the antenna port.
J2-3	GND	This pad is a ground for the antenna port.



**CAUTION: Electrostatic Sensitive Device. Observe precautions when handling.**

## DM1800-434MR I/O Pad Labels

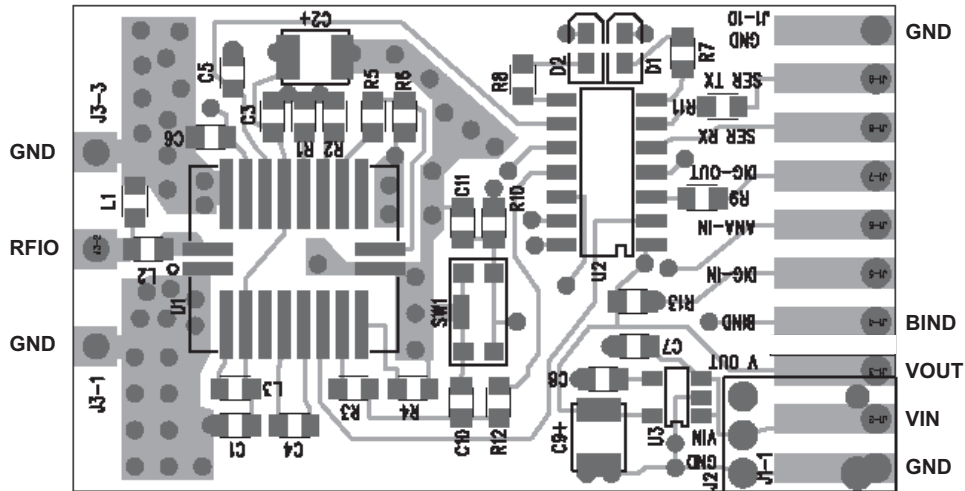
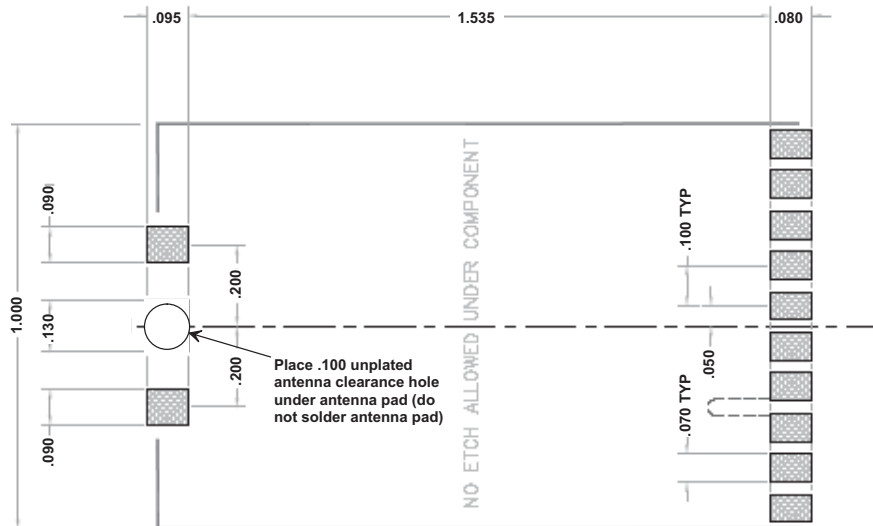

Figure 2

## DM1800-434MR SMT Mounting Pattern



Dimensions in inches. PCB plus component height is .170 max;  
PCB plus antenna height is 1.15 max

Figure 3

Note: Specifications subject to change without notice.