



Induo AB
08-659 43 00
 info@induowireless.com
 www.induowireless.com
 Rökörigatan 19 · 121 63 Johanneshov

DEVELOPER KIT

(Info [Click here](#))

DM1800-434MN

433.92 MHz Transceiver Module



- *Field Node with Host Serial Interface*
- *Compatible with RFM miniMESH™ Network Protocol*

tol

- *3 V, Very Low Current Operation*

The DM1800-434MN is the 433.92 MHz field node module in the DM1800 family of RF transceivers. The DM1800 family is designed for adding wireless mesh connectivity to a wide range of monitoring and control systems. The DM1800-434MN is equipped with a serial I/O port to interface to a host microcontroller. The module also includes an analog input, a logic input, and a logic output for monitoring and control. Radio communications range in an “open field” environment is typically 200 meters/hop. The DM1800-434MN combines RFM’s very low current ASH radio technology with low power microcontroller technology to achieve long battery life. This module is compatible with Cirronet’s miniMESH™ network protocol, which provides add-on “plug- and-play” multicast mesh network routing. The DM1800-434MN is designed for operation under ETSI I-ETS 300 220 regulations.

Absolute Maximum Ratings

Rating	Value	Units
All Input/Output Pins Except VIN	-0.3 to +3.3	V
Non-Operating Ambient Temperature Range	-40 to +85	°C

Electrical Characteristics

Characteristic	Sym	Notes	Minimum	Typical	Maximum	Units
Operating Frequency	f_o		433.72		434.12	MHz
Modulation Type				OOK		
RF Encoded Data Transmission Rate				4.8		kb/s
Average Receiver Input Current, No External Power Supply Load	I_R			4		mA
Receiver Input Signal for 10^{-3} BER, 25 °C				-100		dBm
Peak Transmitter Input Current, No External Power Supply Load	I_{TP}				13.5	mA
Peak Transmitter Output Power	P_O			1		mW
Analog Input Measurement Range (10-bit ADC)			0		VOUT	V
Analog Input Signal Source Impedance					10	K
Bind and Digital In Logic High			2.4			V
Bind and Digital In Logic Low					.45	V
Digital Out Logic High, No Load			2.4			V
Digital Out Logic Low, No Load					0.3	V

Electrical Characteristics

Characteristic	Sym	Notes	Minimum	Typical	Maximum	Units
Digital Output Source Current, 1K load				1.1		mA
Digital Output Sink Current, 1K load				1.2		mA
Serial Port Data Rate			1.2		9.6	kb/s
Average Sleep Input Current, No External Power Supply Load	I _{SA}			90		μA
Power Supply Input Voltage Range	VIN		2.6		10	V
Regulated Power Supply Output Voltage, VIN 3.1 to 10 V	VOUT			3.0		Vdc
Regulated Power Supply Voltage Ripple					10	mV _{P-P}
Operating Temperature Range With Serial Port Operation			0		85	°C
Operating Temperature Range Without Serial Port Operation			-40		85	°C
Relative Humidity Range, Non-Condensing	RH		10		90	%

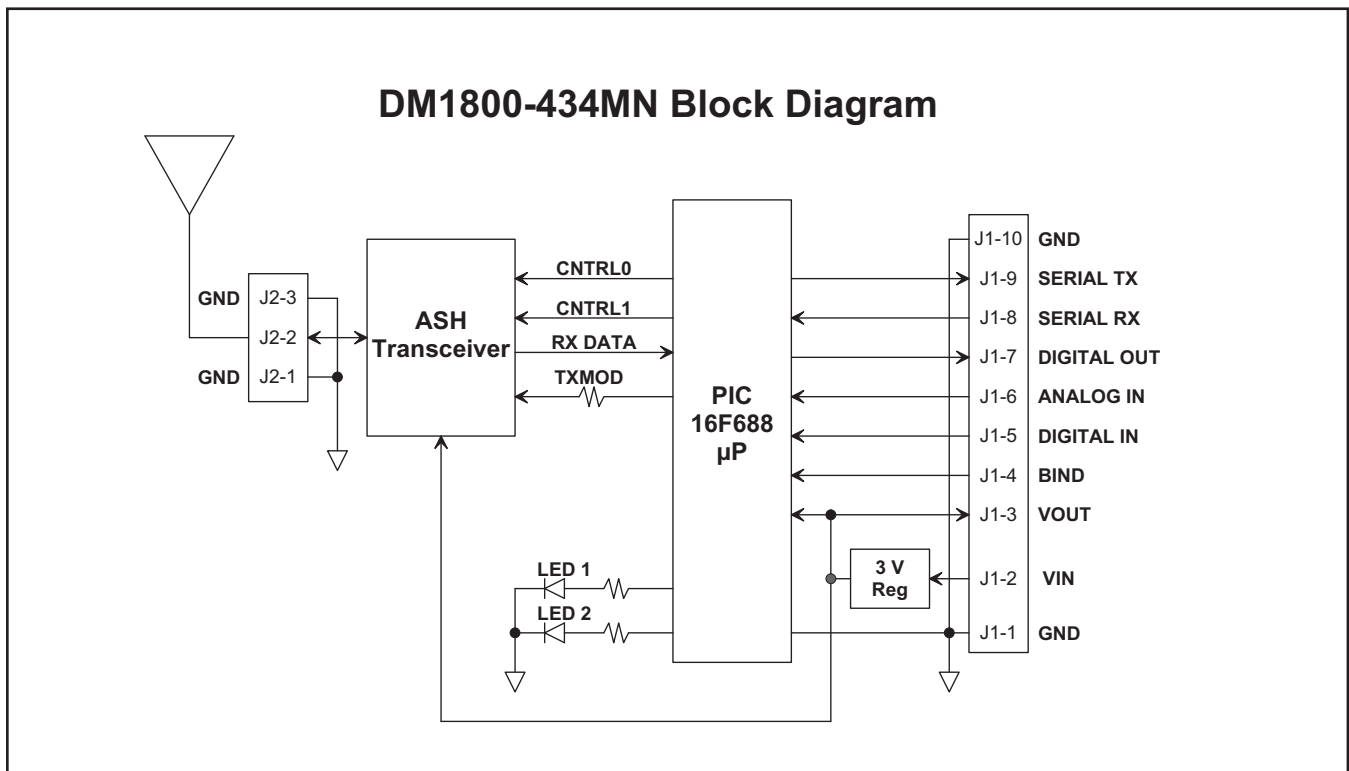

Figure 1

Theory of Operation

The major components of the DM1800-434MN include an RFM TR3000 ASH transceiver and a Microchip PIC16F688 microcontroller. The TR3000 operates on a frequency of 433.92 MHz, at a nominal output power of 1 mW.

The 16F688 provides a 9.6 kb/s serial interface for communication with a host microcontroller. A companion interface board, the IM1800, is also available with USB bridge circuitry to interface the DM1800434MN to a host PC. Three of the 16F688 I/O pins are configured for external monitoring or control. Digital In is configured as a logic input with a weak pull-up for sensing a contact closure to a DM1800 ground pad. Digital Out is configured a logic output. Analog In is configured as a 10-bit analog-to-digital input. The DM1800 includes two LEDs that indicate the module's operating mode.

The DM1800-434MN firmware is based on Cirronet's miniMESH network protocol, which utilizes time-synchronized redundant routing to provide robust, deterministic packet delivery though a network with up to 7 routers. Network configuration and maintenance features are built into the miniMESH protocol, simplifying commissioning and operating logistics.

The DM1800-434MN application programming interface (API) provides straightforward, flexible support for the serial port, ADC input, digital input and digital output, including event messaging from field nodes. The firmware also includes several sleep cycling methods for extended battery life operation.

Please refer to the *DM1800 User's Guide* and the *AN1800 series Application Notes* for installation and application programming information. See Cirronet's web site at www.Cirronet.com.

DM1800-434MN I/O Pad Descriptions

Pin	Name	Description
J1-1	GND	This pad is a signal and power supply ground.
J1-2	VIN	This is the power supply input pad. The allowed input voltage range is 2.6 to 10 V.
J1-3	VOUT	VOUT tracks 50 to 100 mV below VIN when VIN is in the range of 2.6 to 3.1 V. When VIN is in the range of 3.1 to 10 V, VOUT is regulated at 3.0 Vdc. Up to 10 mA can be supplied from this pad for powering external circuits such as thermistor-resistor networks. External circuitry must not impress more than 10 mV _{p-p} ripple on the regulated output voltage.
J1-4	BIND	This pad is connected to a logic input on the microcontroller, and is configured with a weak pull-up. When this pin is momentarily grounded (to J1-1 or J1-10), the module is placed into the bind mode, allowing this module to be associated with other modules to form a network.
J1-5	DIGITAL IN	This pad is connected to a logic input on the microcontroller, and is configured with a weak pull-up, allowing both logic signals and contact closures referenced to J-1 or J-10 to be read. The value of this input is sent over the RF channel as a response to an RF command. The input voltage range on this pad is 0 to VOUT. Applying a voltage outside of this range may damage the module.
J1-6	ANALOG IN	This pad is the input to the microcontroller's 10-bit analog-to-digital (ADC) converter. The ADC input range is 0 to VOUT, referenced to J1-1 or J1-10. The input voltage range on this pad is 0 to VOUT. Applying a voltage outside of this range may damage the module. The ADC reading is sent over the RF channel as a response to an RF command.
J1-7	DIGITAL OUT	This pad is connected to a logic output on the microcontroller through a 1 kilohm resistor, which provides short-circuit protection. The value of this output is set or read over the RF channel as a response to an RF command.
J1-8	SERIAL RX	This pad is connected to the module's serial data input (USART). Data to this pin is received at 9.6 kb/s (default), using 8 data bits, no parity, one stop bit. The input voltage range on this pad is 0 to VOUT. Applying a voltage outside of this range may damage the module.
J1-9	SERIAL TX	This pad is connected to the module's serial data output (USART) through a 1 kilohm resistor, which provides short-circuit protection. Data from this pad is sent at 9.6 kb/s (default), using 8 data bits, no parity, one stop bit.
J1-10	GND	This pad is a signal and power supply ground.
J2-1	GND	This pad is a ground for the antenna port.
J2-2	ANT	This pad is the antenna port.
J2-3	GND	This pad is a ground for the antenna port.



CAUTION: Electrostatic Sensitive Device. Observe precautions when handling.

DM1800-434MN I/O Pad Labels

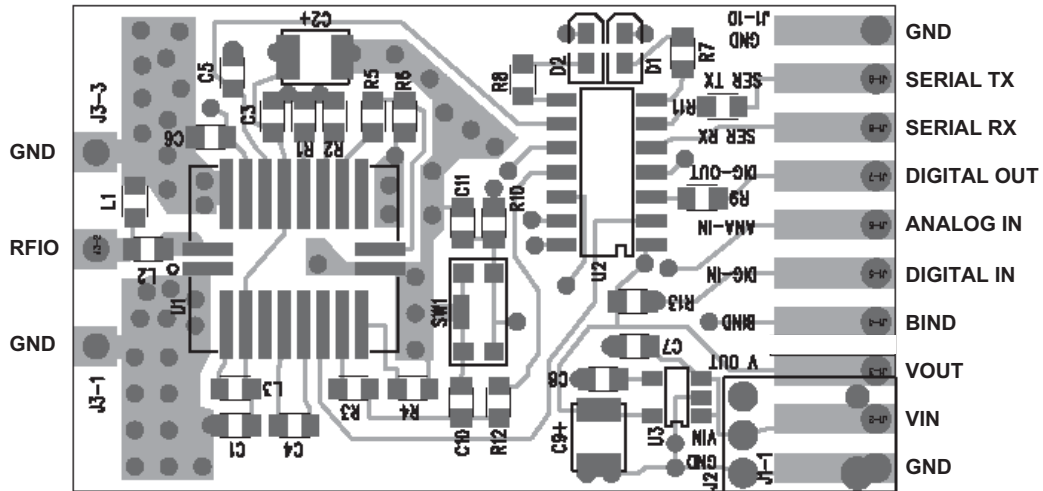
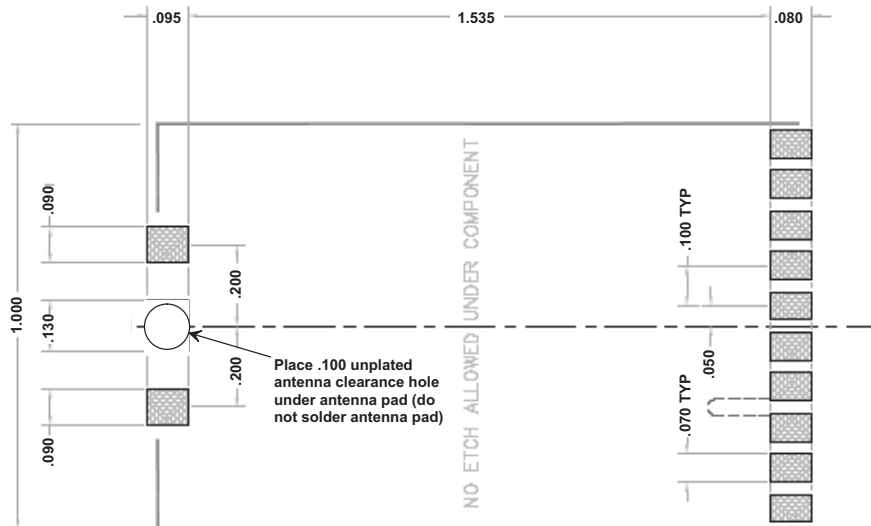

Figure 2

DM1800-434MN SMT Mounting Pattern



Dimensions in inches. PCB plus component height is .170 max;
PCB plus antenna height is 1.15 max

Figure 3

Note: Specifications subject to change without notice.