



Induo AB
08-659 43 00
 info@induowireless.com
 www.induowireless.com
 Rökerigatan 19 · 121 63 Johanneshov

DEVELOPER KIT
 (Info [Click here](#))

DM1800-434MB

433.92 MHz Transceiver Module

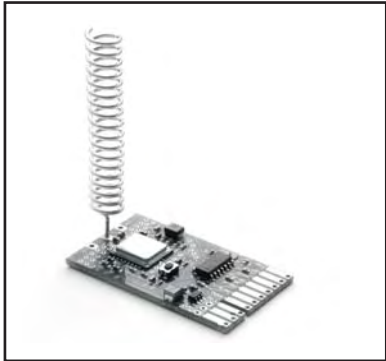

- *Base Station with Host Serial Interface*
- *Compatible with RFM miniMESH™ Network Protocol*
- *3 V, Very Low Current Operation*
- *Ready-to-Use OEM Module*

The DM1800-434MB is the 433.92 MHz base station module in the DM1800 family of RF transceivers. The DM1800 family is designed for adding wireless mesh network connectivity to a wide range of monitoring and control systems. The DM1800-434MB is equipped with a serial I/O port to interface a host microcontroller. Radio communications range in an “open field” environment is typically 200 meters/hop. The DM1800-434MB combines RFM’s very low current ASH radio technology with low power microcontroller technology to achieve long battery life. This module is compatible with RFM miniMESH™ network protocol, which provides add-on “plug- and-play” multicast mesh network routing. The DM1800-434MB is designed for operation under ETSI I-ETS 300 220 regulations.

Absolute Maximum Ratings

Rating	Value	Units
All Input/Output Pins Except VIN	-0.3 to +3.3	V
Non-Operating Ambient Temperature Range	-40 to +85	°C

Electrical Characteristics

Characteristic	Sym	Notes	Minimum	Typical	Maximum	Units
Operating Frequency	f _o		433.72		434.12	MHz
Modulation Type			OOK			
RF Encoded Data Transmission Rate				4.8		kb/s
Average Receiver Input Current, No External Power Supply Load	I _R			4		mA
Receiver Input Signal for 10 ⁻³ BER, 25 °C				-100		dBm
Peak Transmitter Input Current, No External Power Supply Load	I _{TP}				13.5	mA
Peak Transmitter Output Power	P _O			1		mW
Bind Input Logic High			2.4			V
Bind Input Logic Low					.45	V
Serial Port Data Rate				9.6		kb/s
Average Sleep Input Current, No External Power Supply Load	I _{SA}			90		µA
Power Supply Input Voltage Range	VIN		2.6		10	V
Regulated Power Supply Output Voltage, VIN 3.1 to 10 V	VOU			3.0		Vdc
Regulated Power Supply Voltage Ripple					10	mV _{P-P}
Operating Temperature Range			0		85	°C

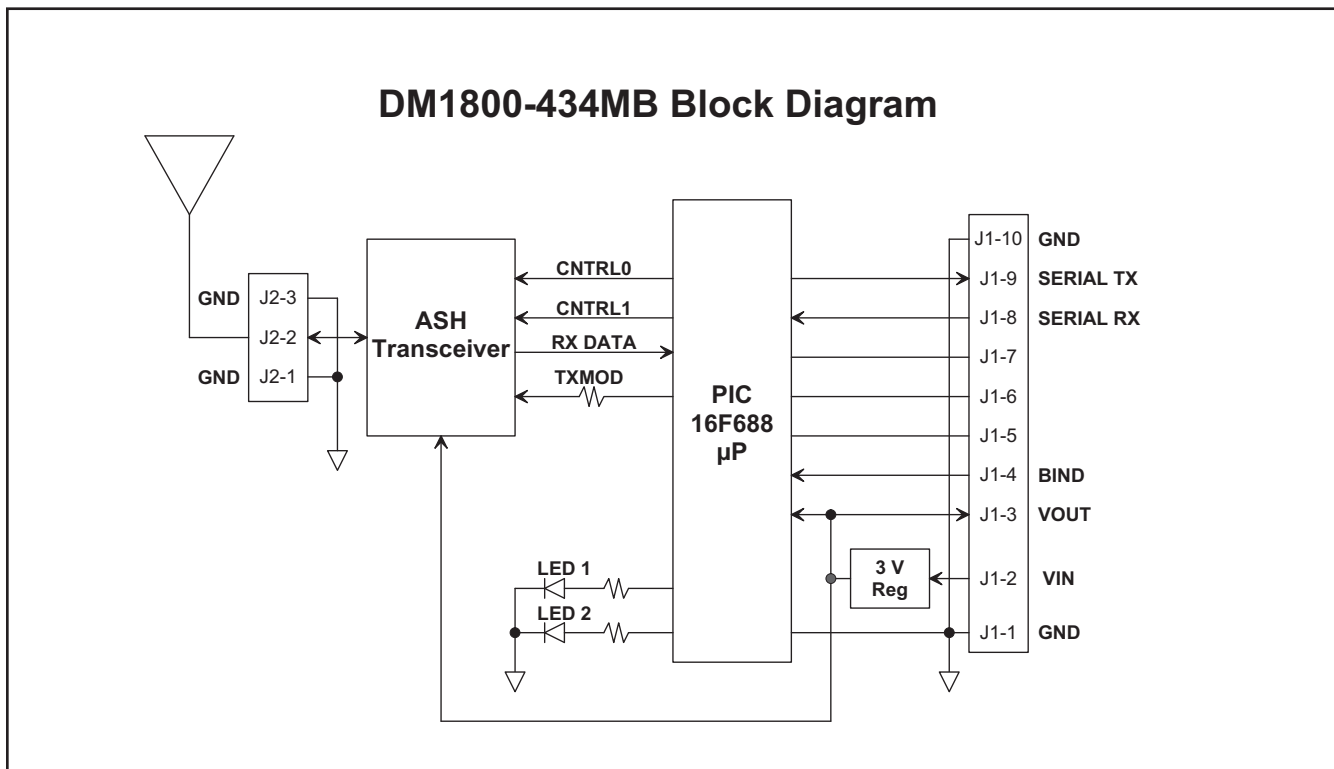

Figure 1

Theory of Operation

The major components of the DM1800- 433.92MB include an RFM TR3000 ASH transceiver and a Microchip PIC16F688 microcontroller. The TR3000 operates on a frequency of 433.92 MHz, at a nominal output power of 1 mW.

The 16F688 provides a 9.6 kb/s serial interface for communication with a host micro- controller. A companion interface board, the IM1800, is also available with USB bridge circuitry to interface the DM1800 to a host PC.

The DM1800-434MB includes two LEDs that indicate the module’s operating mode.

The DM1800-434MB firmware is based on RFM’s miniMESH network protocol, which utilizes time-synchronized redundant routing to provide robust, deterministic packet delivery though a network with up to 7 routers. Network configuration and maintenance features are built into the miniMESH protocol, simplifying commissioning and operating logistics. The firmware also includes several sleep cycling methods for extended battery life operation.

Please refer to the *DM1800 User’s Guide* and the *AN1800 series Application Notes* for installation and application programming information. See RFM’s web site at www.RFM.com.

DM1800-434MB I/O Pad Descriptions

Pin	Name	Description
J1-1	GND	This pad is a signal and power supply ground.
J1-2	VIN	This is the power supply input pad. The allowed input voltage range is 2.6 to 10 V.
J1-3	VOUT	VOUT tracks 50 to 100 mV below VIN when VIN is in the range of 2.6 to 3.1 V. When VIN is in the range of 3.1 to 10 V, VOUT is regulated at 3.0 Vdc. Up to 10 mA can be supplied from this pad for powering external circuits such as thermistor-resistor networks. External circuitry must not impress more than 10 mV _{p-p} ripple on the regulated output voltage.
J1-4	BIND INPUT	This pad is connected to a logic input on the microcontroller, and is configured with a weak pull-up. When this pin is momentarily grounded (to J1-1 or J1-10), the module is placed into the bind mode, allowing this module to be associated with other modules to form a network.
J1-5	-	This pad is unused in base station operation. Leave this pad electrically unconnected.
J1-6	-	This pad is unused in base station operation. Leave this pad electrically unconnected.
J1-7	-	This pad is unused in base station operation. Leave this pad electrically unconnected.
J1-8	SERIAL RX	This pad is connected to the module's serial data input (USART). Data to this pin is received at 9.6 kb/s, using 8 data bits, no parity, and one stop bit. The input voltage range on this pad is 0 to VOUT. Applying a voltage outside of this range may damage the module.
J1-9	SERIAL TX	This pad is connected to the module's serial data output (USART) through a 1 kilohm resistor, which provides short-circuit protection. Data from this pad is sent at 9.6 kb/s, using 8 data bits, no parity, and one stop bit.
J1-10	GND	This pad is a signal and power supply ground.
J2-1	GND	This pad is a ground for the antenna port.
J2-2	ANT	This pad is the antenna port.
J2-3	GND	This pad is a ground for the antenna port.

CAUTION: Electrostatic Sensitive Device. Observe precautions when handling.

DM1800-434MB I/O Pad Labels

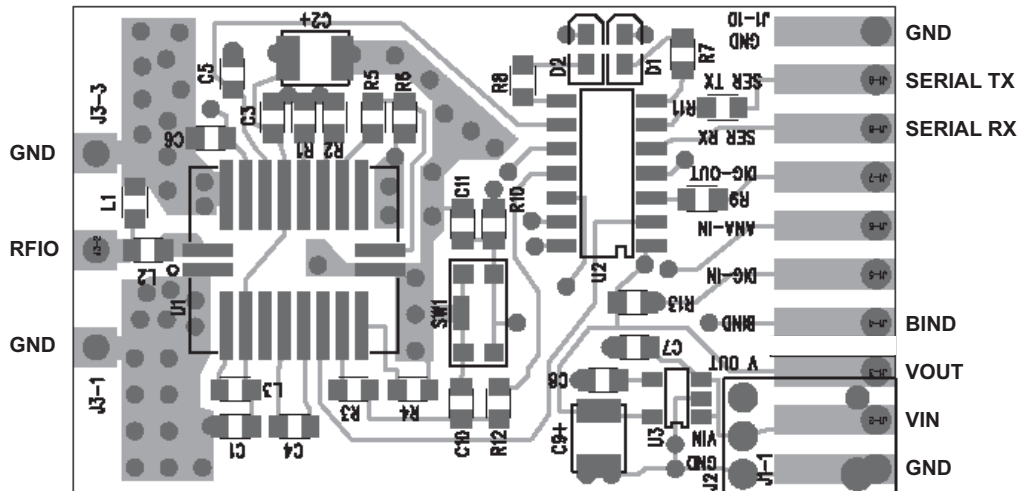
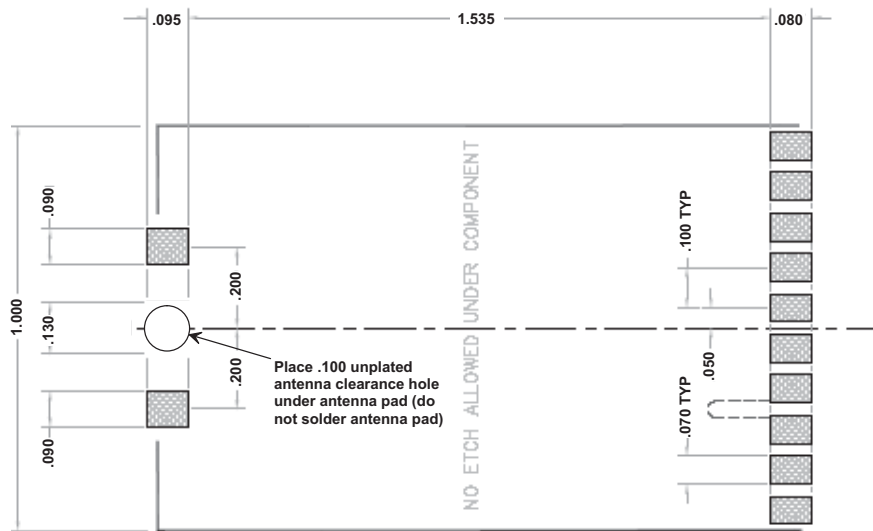

Figure 2

DM1800-434MB SMT Mounting Pattern



Dimensions in inches. PCB plus component height is .170 max;
PCB plus antenna height is 1.15 max

Figure 3

Note: Specifications subject to change without notice.